

Turbine Series filter assemblies are designed to be installed on the vacuum side of the fuel transfer pump for best efficiency and protect precision engine components from dirt, rust, algae, asphaltines, varnishes, and especially water, which is prevalent in engine fuels. They remove contaminants from fuel using the following legendary three stage process:

### Stage One: Separation

As fuel enters the assembly, it moves through the centrifuge and spins off large solids and water droplets which fall to the bottom of the collection bowl.

### Stage Two: Coalescing

Small water droplets bead-up on the surface of the conical baffle and cartridge element. When heavy enough, they too fall to the bottom of the bowl.

### Stage Three: Filtration

Proprietary Aquabloc II cartridge elements repel water and remove contaminants from fuel down to two micron (nominal). They are waterproof and effective longer than water absorbing elements.

### Features and Benefits

- Available in several sizes to fit any application.
- Heavy duty construction.
- Installs quickly.
- Available in 2, 10 & 30 micron.
- Easy to service.
- See-thru collection bowl.
- Self-venting water drain.

Optional accessories may include: water detection kits, 12 or 24 volt heaters, vacuum or compound gauges, heavy-duty fuel hose and fittings.



500FG

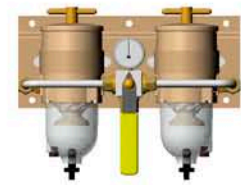

75500FGX



900FH

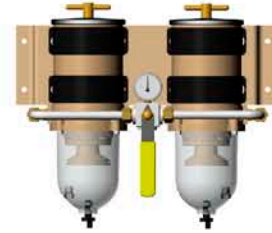

75900FHX



1000FH

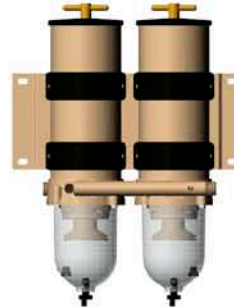

731000FH

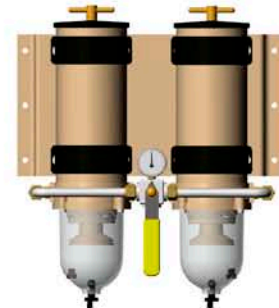

751000FHX

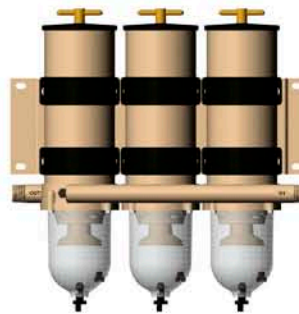

771000FH

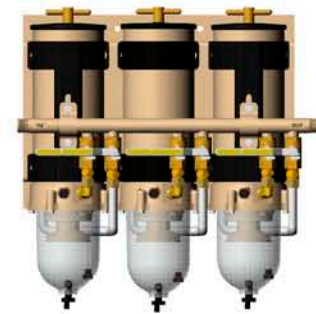

791000FHV



## Specifications

Basic Models	500FG	900FH	1000FH
<b>Maximum Flow Rate:</b> (one unit online) (two units online) (three units online)	60 GPH (227 LPH) N/A N/A	90 GPH (341 LPH) N/A N/A	180 GPH (681 LPH) N/A N/A
<b>Port Size</b> (female threads)	3/4"-16 UNF (SAE J1926)	7/8"-14 UNF (SAE J1926)	7/8"-14 UNF (SAE J1926)
<b>Min. Service Clearance</b> (above assembly) (below assembly)	5.0 in. (12.7 cm) 2.0 in. (5.1 cm)	7.5 in. (19.1 cm) 2.0 in. (5.1 cm)	10.0 in. (25.4 cm) 2.0 in. (5.1 cm)
<b>Replacement Element:</b> (2 micron) (10 micron) (30 micron)	(1 Per Assembly) 2010SM-OR 2010TM-OR 2010PM-OR	(1 Per Assembly) 2040SM-OR 2040TM-OR 2040PM-OR	(1 Per Assembly) 2020SM-OR 2020TM-OR 2020PM-OR
<b>Height</b>	11.5 in. (29.2 cm)	17.0 in. (43.2 cm)	22.0 in. (55.9 cm)
<b>Depth</b>	4.8 in. (12.2 cm)	7.0 in. (17.8 cm)	7.0 in. (17.8 cm)
<b>Width</b>	5.8 in. (14.7 cm)	6.0 in. (15.2 cm)	6.0 in. (15.2 cm)
<b>Weight</b> (dry)	4.0 lb (1.8 kg)	6.0 lb (2.7 kg)	10.0 lb (4.5 kg)
<b>Clean Pressure Drop</b>	0.25 PSI (1.7 kPa)	0.30 PSI (2.1 kPa)	0.43 PSI (3.0 kPa)
<b>Maximum Pressure</b> <sup>1</sup>	15 PSI (1 bar)	15 PSI (1 bar)	15 PSI (1 bar)
<b>Water In Bowl Capacity</b> (per bowl)	3.7 oz (110 ml)	10.3 oz (305 ml)	10.3 oz (305 ml)
<b>Available Options:</b> <sup>2</sup> (water detection kit) (12 or 24 vdc heater) (vacuum gauge)	Yes Yes Yes	Yes Yes Yes	Yes Yes Yes
<b>Operating Temperature</b>	-40° to +255°F / -40° to +121°C		

<sup>1</sup> Pressure installations are applicable up to the maximum PSI shown. Vacuum installations are recommended.

<sup>2</sup> Not for use on gasoline applications.

# Turbine Series

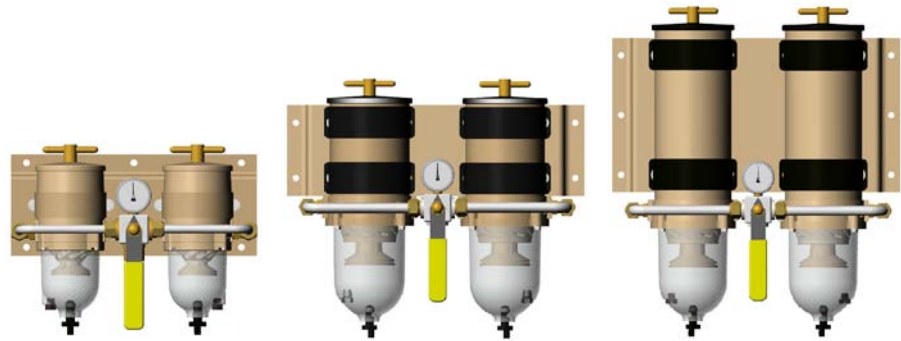

## Specifications

Basic Models	75500FGX	75900FHX	751000FHX
<b>Maximum Flow Rate:</b> (one unit online) (two units online) (three units online)	60 GPH (227 LPH) 120 GPH (454 LPH) N/A	90 GPH (341 LPH) 180 GPH (681 LPH) N/A	180 GPH (681 LPH) 360 GPH (1363 LPH) N/A
<b>Port Size</b>	3/4"-16 UNF (SAE J1926 female threads)	7/8"-14 UNF (SAE J514 male threads)	7/8"-14 UNF (SAE J514 male threads)
<b>Min. Service Clearance</b> (above assembly) (below assembly)	5.0 in. (12.7 cm) 2.0 in. (5.1 cm)	7.5 in. (19.1 cm) 2.0 in. (5.1 cm)	10.0 in. (25.4 cm) 2.0 in. (5.1 cm)
<b>Replacement Element:</b> (2 micron) (10 micron) (30 micron)	(2 Per Assembly) 2010SM-OR 2010TM-OR 2010PM-OR	(2 Per Assembly) 2040SM-OR 2040TM-OR 2040PM-OR	(2 Per Assembly) 2020SM-OR 2020TM-OR 2020PM-OR
<b>Height</b>	11.5 in. (29.2 cm)	17.0 in. (43.2 cm)	22.0 in. (55.9 cm)
<b>Depth</b>	9.5 in. (24.1 cm)	11.0 in. (27.9 cm)	11.0 in. (27.9 cm)
<b>Width</b>	14.5 in. (36.8 cm)	18.8 in. (47.8 cm)	18.8 in. (47.8 cm)
<b>Weight (dry)</b>	17.0 lb (7.7 kg)	23.0 lb (10.4 kg)	30.0 lb (13.6 kg)
<b>Clean Pressure Drop</b>	0.7 PSI (4.8 kPa)	1.7 PSI (11.7 kPa)	3.7 PSI (25.5 kPa)
<b>Maximum Pressure<sup>1</sup></b>	15 PSI (1 bar)	15 PSI (1 bar)	15 PSI (1 bar)
<b>Water In Bowl Capacity</b> (per bowl)	3.7 oz (110 ml)	10.3 oz (305 ml)	10.3 oz (305 ml)
<b>Available Options:<sup>2</sup></b> (water detection kit) (12 or 24 vdc heater) (vacuum gauge)	Yes Yes Yes	Yes Yes Yes	Yes Yes Yes
<b>Operating Temperature</b>	-40° to +255°F / -40° to +121°C		

<sup>1</sup> Pressure installations are applicable up to the maximum PSI shown. Vacuum installations are recommended.

<sup>2</sup> Not for use on gasoline applications.

**Racor Technical Support:**  
1-800-344-3286 ext. 7555  
racortech@parker.com



**How To Order** (The example below illustrates how part numbers are constructed.)

<b>500FG</b>	<b>12</b>	<b>2</b>
Specify ' <b>500FG</b> ' for 3/4"-16 UNF ports or ' <b>*500FG</b> ' for 16M ports.	Add ' <b>12</b> ' for a 12 volt dc heater <u>or</u> ' <b>24</b> ' for a 24 volt dc heater <sup>†</sup> . (omit if not desired)	Specify a micron rating: ' <b>2</b> ', ' <b>10</b> ', <u>or</u> ' <b>30</b> '.
† 150 watt heater, recommended for use with a Racor relay kit. See Accessories.		

<b>Replacement Elements</b> (seals included)		
<b>2 Micron</b> (Final Filtration)	<b>10 Micron</b> (Secondary Filtration)	<b>30 Micron</b> (Primary Filtration)
<b>2010SM-OR</b>	<b>2010TM-OR</b>	<b>2010PM-OR</b>

**Mounting Instructions**

**Note:** Mount filter assembly as close to vertical (**V**) as possible. For best efficiency, do not exceed 10° from **V**.

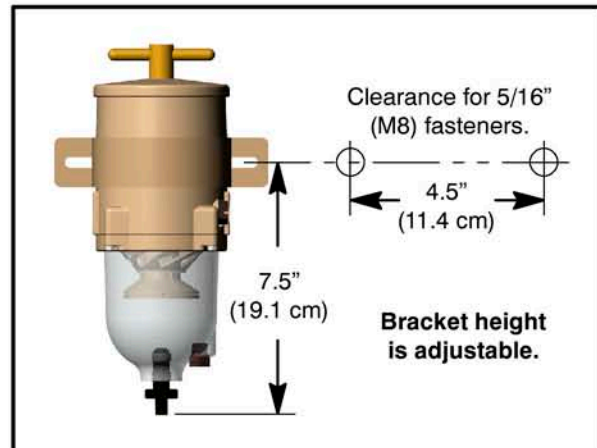
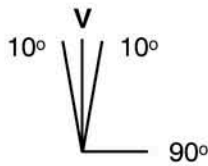

**Performance Data** (Controlled laboratory tests. Field results may vary.)  
(PSI X 2.036 = inHg) (PSI X 6.895 = kPa)

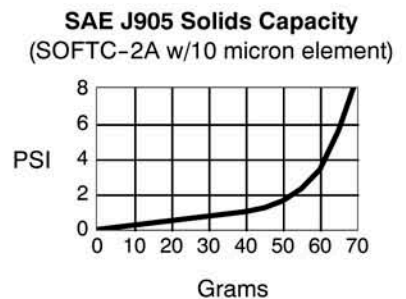
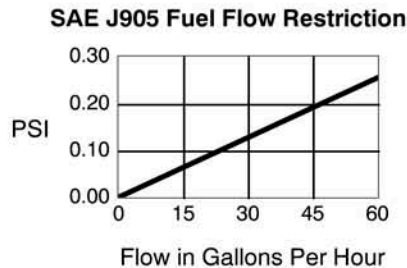
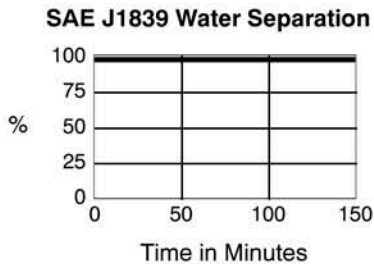

**500FG Replacement Parts**

<u>Part Number</u>	<u>Description</u>
1 <b>RK15378</b> <b>RK11838</b>	Mounting Bracket Kit Bracket Hardware Kit (5/16"-18, not shown)
2 <b>RK15377-01</b> <b>RK15377-02</b>	Body Kit (3/4"-16 UNF Ports) Body Kit (16M X 1.5 Ports)
3 <b>RK15035</b>	Bowl Ring Kit
4 <b>RK15081</b>	Hex Head Capscrews Kit (Includes 4, 10-24 x 7/8")
5 <b>RK15405</b>	See-thru Bowl Kit (Includes bowl, drain, bowl gasket and probe plug)
<b>RK15301</b>	Metal Bowl Kit (not shown) (Includes 1/4" NPT Drain)
6 <b>RK11-1945</b>  <b>11350</b>	T-handle and O-ring Kit (9/16"-18 UNF Threads) T-handle O-ring
7 <b>RK15078</b> <b>15005</b>	Lid and Lid Gasket Kit Lid Gasket
8 <b>RK15397</b>	Return Tube Kit
9 (All replacement elements include seals) <b>2010SM-OR</b> <b>2010TM-OR</b> <b>2010PM-OR</b>	2 Micron Element 10 Micron Element 30 Micron Element
10 (Heater kits include item #11) <b>RK15383-01</b> <sup>1</sup> <b>RK15383-02</b> <sup>1</sup>	Heater Kit (12 vdc, 150 watt) Heater Kit (24 vdc, 150 watt)
11 <b>RK21067</b> <b>RK11-1679</b>	Feed-thru Assy Kit (for heate Feed-thru Plug Kit (not show)
12 <b>15374</b>	Bowl Gasket
13 <b>RK15010B</b>	Check Ball with Seal Kit
14 <b>RK15013D</b>	Centrifuge/Conical Baffle Kit
15 <b>RK20126</b>	Water Probe Port Plug Kit
16 <b>RK21069</b> <sup>2</sup>	Water Sensor Probe Kit

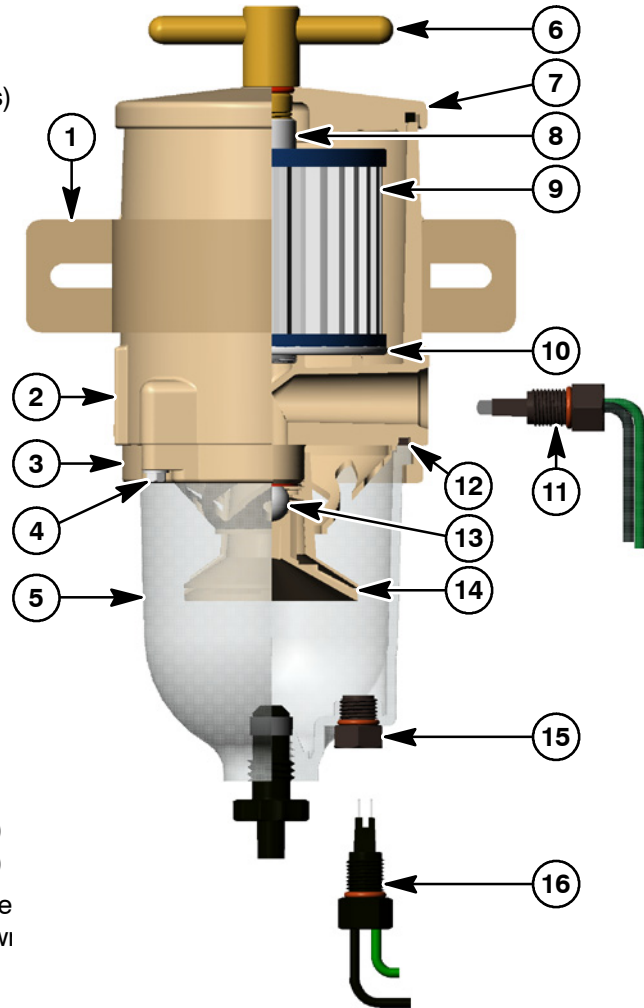

Additional Parts (not shown)

<b>RK15211</b>	Complete Seal Service Kit
----------------	---------------------------

Notes:

<sup>1</sup> In-filter heater kits require a Heater Relay Kit – see Accessories section of this catalog. Maximum power requirements for in-filter heaters are: 12.5 amps for 12 vdc and 6.3 amps for 24 vdc.

<sup>2</sup> Water probe must be used with Water Detection Kit – see Accessories section of this catalog.

**Racor Technical Support:**

1-800-344-3286 ext. 7555  
racortech@parker.com



## How To Order (The example below illustrates how part numbers are constructed.)

<b>900FH</b>	<b>312</b>	<b>2</b>
Specify '900FH' for 7/8"-14 UNF ports or '902FH' for 22M ports.	Add '312' for a 12 volt dc heater or '324' for a 24 volt dc heater <sup>1</sup> . (omit if not desired)	Specify a micron rating: '2', '10', or '30'.
<sup>1</sup> 300 watt heater, recommended for use with a Racor relay kit. See Accessories.		

Replacement Elements (seals included)		
<b>2 Micron</b> (Final Filtration)	<b>10 Micron</b> (Secondary Filtration)	<b>30 Micron</b> (Primary Filtration)
<b>2040SM-OR</b>	<b>2040TM-OR</b>	<b>2040PM-OR</b>

## Mounting Instructions

**Note:** Mount filter assembly as close to vertical (**V**) as possible. For best efficiency, do not exceed 10° from **V**.

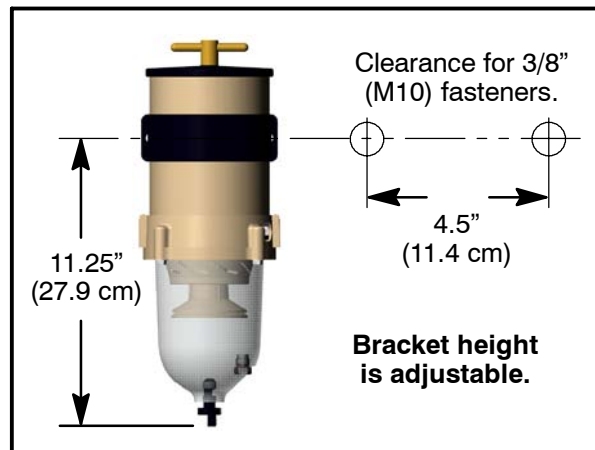
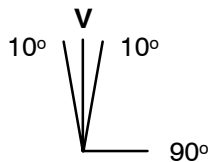

## Performance Data (Controlled laboratory tests. Field results may vary.)

(PSI X 2.036 = inHg) (PSI X 6.895 = kPa)

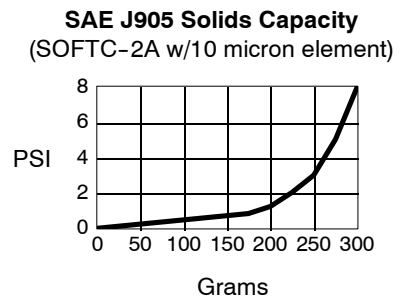
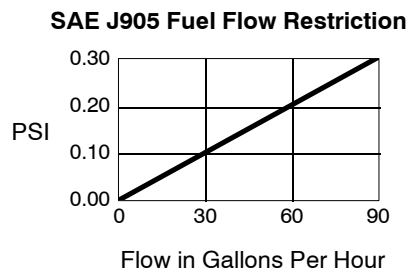
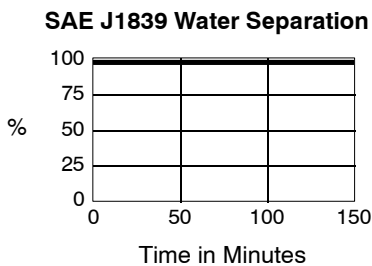

**900FH Replacement Parts**

<u>Part Number</u>	<u>Description</u>
1 <b>RK11-1945</b>	T-handle and O-ring Kit (9/16"-18 UNF Threads)
<b>11350</b>	T-handle O-ring (not shown)
2 <b>RK11-1927-01</b>	Lid and Lid Gasket Kit
<b>11007</b>	Lid (and Bowl) Gasket
3 <b>RK19002-03</b>	Outer Cylinder Kit
4 <b>RK11-1931</b>	Return Tube Kit
5 <b>RK11815-103</b>	Mounting Bracket Kit (Includes bracket hardware)
6	(All replacement elements include seals)
<b>2040SM-OR</b>	2 Micron Element
<b>2040TM-OR</b>	10 Micron Element
<b>2040PM-OR</b>	30 Micron Element
7 <b>RK11-1953</b>	Valve, Spring & O-ring Kit
8	(Heater kits include item #9)
<b>RK11-1800-01<sup>1</sup></b>	Heater Kit (12 vdc, 300 watt)
<b>RK11-1800-02<sup>1</sup></b>	Heater Kit (24 vdc, 300 watt)
9 <b>RK21067</b>	Feed-thru Assy Kit (for heater)
<b>RK11-1679</b>	Feed-thru Plug Kit (not shown)
10 <b>11007</b>	Bowl (and Lid) Gasket
11 <b>RK11028B</b>	Check Ball with Seal Kit
12 <b>RK11-1939</b>	Centrifuge/Conical Baffle Kit
13 <b>RK32204<sup>2</sup></b>	Water Sensor Probe Kit
<b>RK22838</b>	Water Probe Port Plug Kit
14 <b>RK11-1776</b>	Body Kit (with 7/8"-14 UNF Ports)
<b>RK11-1776-02</b>	Body Kit (with 22M X 1.5 Ports)
15 <b>RK11037A</b>	Bowl Ring Kit (5" Diameter)
16 <b>RK11542</b>	Capscrew Kit (4)
17 <b>RK11-1938</b>	See-thru Bowl Kit (Includes bowl, drain, bowl gasket and probe plug)

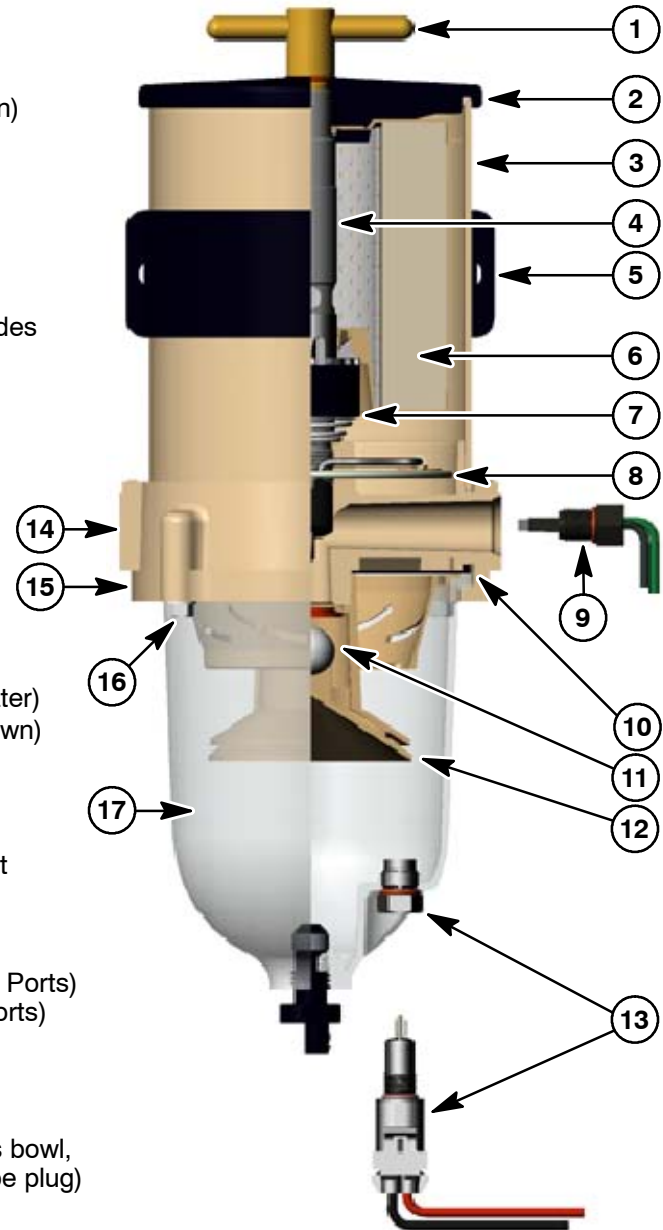

Additional Parts (not shown)

<b>RK11-1952</b>	Complete Seal Service Kit
------------------	---------------------------

Notes:

<sup>1</sup> In-filter heater kits require a Heater Relay Kit – see Accessories section of this catalog. Maximum power requirements for in-filter heaters are: 25 amps for 12 vdc and 12.5 amps for 24 vdc.

<sup>2</sup> Water probe must be used with Water Detection Kit – see Accessories section of this catalog. Water probe features a detachable harness connector.

**Racor Technical Support:**

1-800-344-3286 ext. 7555  
racortech@parker.com



**How To Order** (The example below illustrates how part numbers are constructed.)

<b>1000FH</b>	<b>312</b>	<b>2</b>
Specify '1000FH' for 7/8"-14 UNF ports or '1002FH' for 22M ports.	Add '312' for a 12 volt dc heater or '324' for a 24 volt dc heater <sup>1</sup> . (omit if not desired)	Specify a micron rating: '2', '10', or '30'.
<sup>1</sup> 300 watt heater, recommended for use with a Racor relay kit. See Accessories.		

<b>Replacement Elements</b> (seals included)		
<b>2 Micron</b> (Final Filtration)	<b>10 Micron</b> (Secondary Filtration)	<b>30 Micron</b> (Primary Filtration)
<b>2020SM-OR</b>	<b>2020TM-OR</b>	<b>2020PM-OR</b>

**Mounting Instructions**

**Note:** Mount filter assembly as close to vertical (V) as possible. For best efficiency, do not exceed 10° from V.

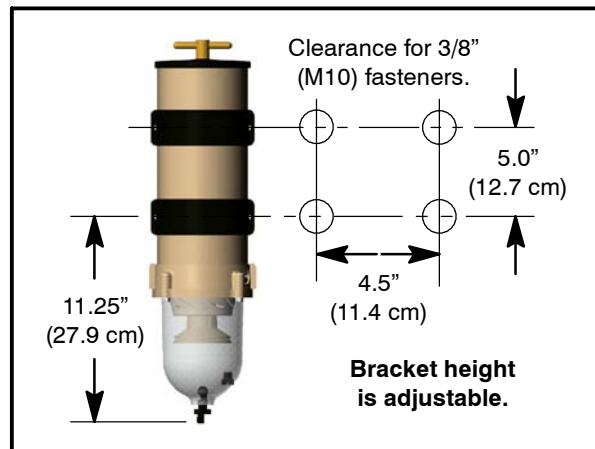
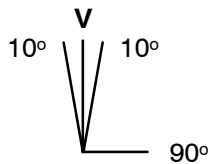

**Performance Data** (Controlled laboratory tests. Field results may vary.)  
 (PSI X 2.036 = inHg) (PSI X 6.895 = kPa)

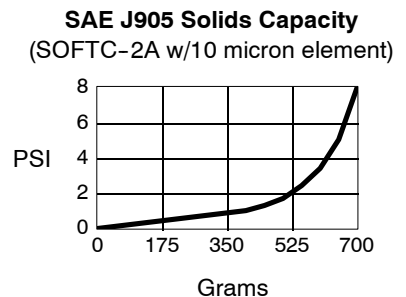
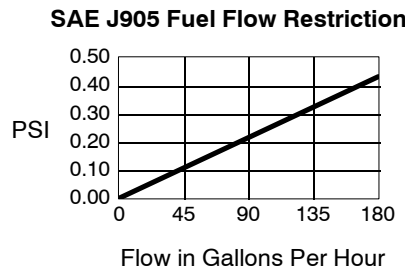
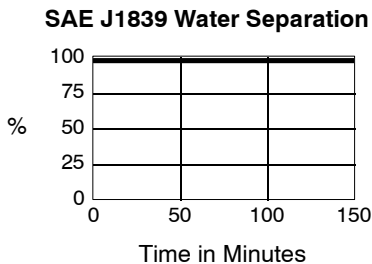

## 1000FH Replacement Parts

	<u>Part Number</u>	<u>Description</u>
1	<b>RK11-1945</b> <b>11350</b>	T-handle and O-ring Kit (9/16"-18 UNF Threads) T-handle O-ring (not shown)
2	<b>RK11-1927-01</b> <b>11007</b>	Lid and Gasket Kit Lid (and Bowl) Gasket
3	<b>RK11021-03</b>	Outer Cylinder Kit
4	<b>RK11-1930</b>	Return Tube Kit
5	<b>RK11815-103</b>	Mounting Bracket (Includes bracket hardware)
6	(All replacement elements include seals) <b>2020SM-OR</b> <b>2020TM-OR</b> <b>2020PM-OR</b>	2 Micron Element 10 Micron Element 30 Micron Element
7	<b>RK11-1953</b>	Valve, Spring & O-ring Kit
8	(Heater kits include item #9) <b>RK11-1800-01</b> <sup>1</sup> <b>RK11-1800-02</b> <sup>1</sup>	Heater (12 vdc, 300 watt) Heater (24 vdc, 300 watt)
9	<b>RK21067</b> <b>RK11-1679</b>	Feed-thru Assy (for heater) Feed-thru Plug (not shown)
10	<b>11007</b>	Bowl (and Lid) Gasket
11	<b>RK11028B</b>	Check Ball with Seal
12	<b>RK11-1939</b>	Centrifuge/Conical Baffle
13	<b>RK32204</b> <sup>2</sup> <b>RK22838</b>	Water Sensor Probe Water Probe Port Plug
14	<b>RK11-1776</b> <b>RK11-1776-02</b>	Body (with 7/8"-14 UNF Ports) Body Kit (with 22M X 1.5 Ports)
15	<b>RK11037A</b>	Bowl Ring (5" Diameter)
16	<b>RK11542</b>	Capscrew Kit (4)
17	<b>RK11-1938</b>	See-thru Bowl Kit (Includes bowl, drain, bowl gasket and probe plug)

### Additional Parts (not shown)

<b>RK11-1952</b>	Complete Seal Service Kit
------------------	---------------------------

### Notes:

- <sup>1</sup> In-filter heater kits require a Heater Relay Kit – see Accessories section or this catalog. Maximum power requirements for in-filter heaters are: 25 amps for 12 vdc and 12.5 amps for 24 vdc.
- <sup>2</sup> Water probe must be used with Water Detection Kit – see Accessories section of this catalog. Water probe features a detachable harness connector.

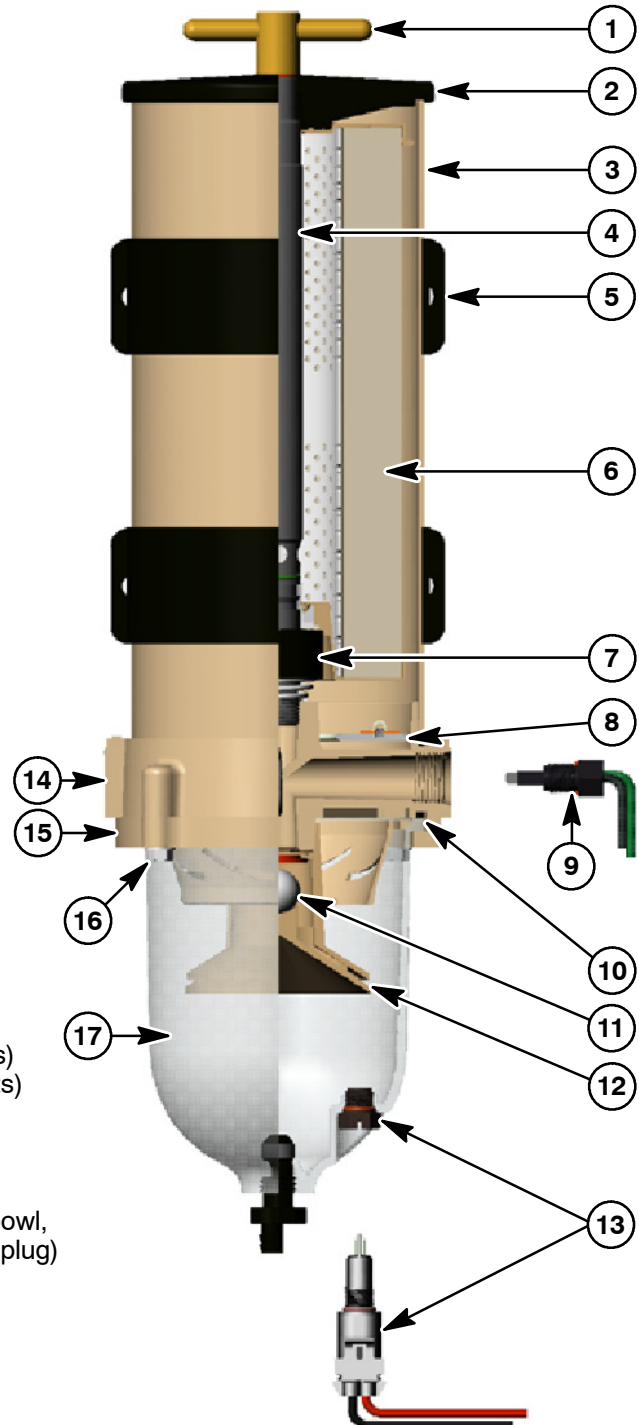

### Racor Technical Support:

1-800-344-3286 ext. 7555  
racortech@parker.com



**How To Order** (The example below illustrates how part numbers are constructed.)

<b>75500FGX</b>	<b>12</b>	<b>2</b>
Base model with 3/4"-16 UNF fuel ports (SAE J1926).	Add '12' for a 12 volt dc heater <u>or</u> '24' for a 24 volt dc heater <sup>†</sup> . (omit if not desired)	Specify a micron rating: '2', '10', <u>or</u> '30'.
† 150 watt heater, recommended for use with a Racor relay kit. See Accessories.		

<b>Replacement Elements</b> (seals included)		
<b>2 Micron</b> (Final Filtration)	<b>10 Micron</b> (Secondary Filtration)	<b>30 Micron</b> (Primary Filtration)
<b>2010SM-OR</b>	<b>2010TM-OR</b>	<b>2010PM-OR</b>
<b>Note:</b> 75500FGX assemblies use TWO elements (one per 500FG housing).		

**Mounting Instructions**

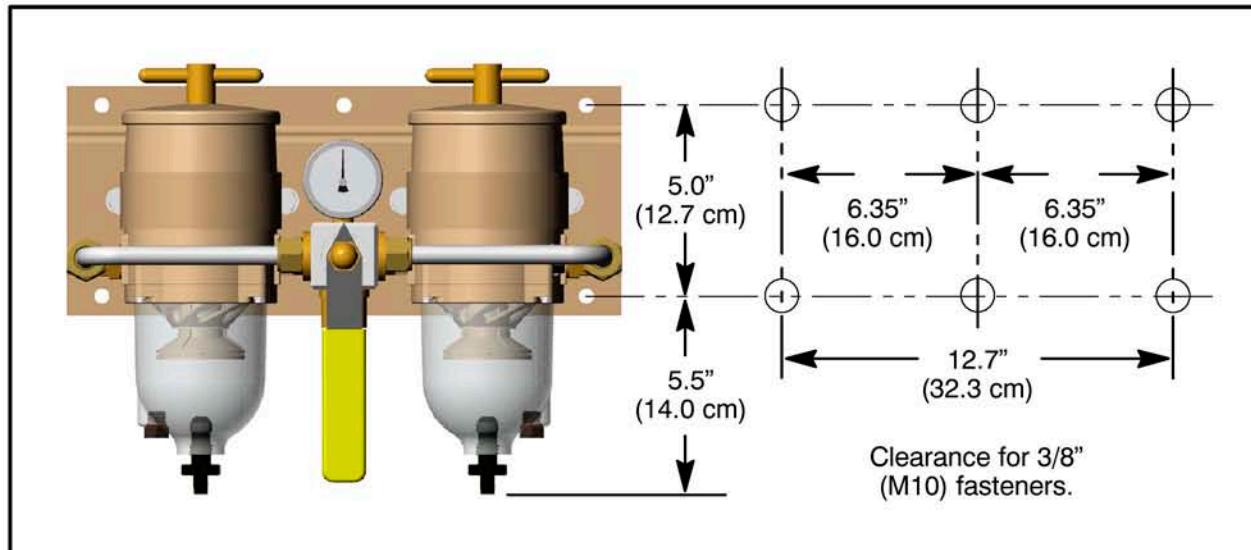

**Notes:** Mount filter assembly as close to vertical (V) as possible. For best efficiency, do not exceed 10° from vertical.

Do not remove valve fittings as they are integral components to the valve body.

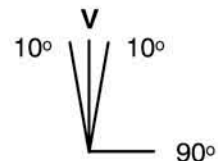

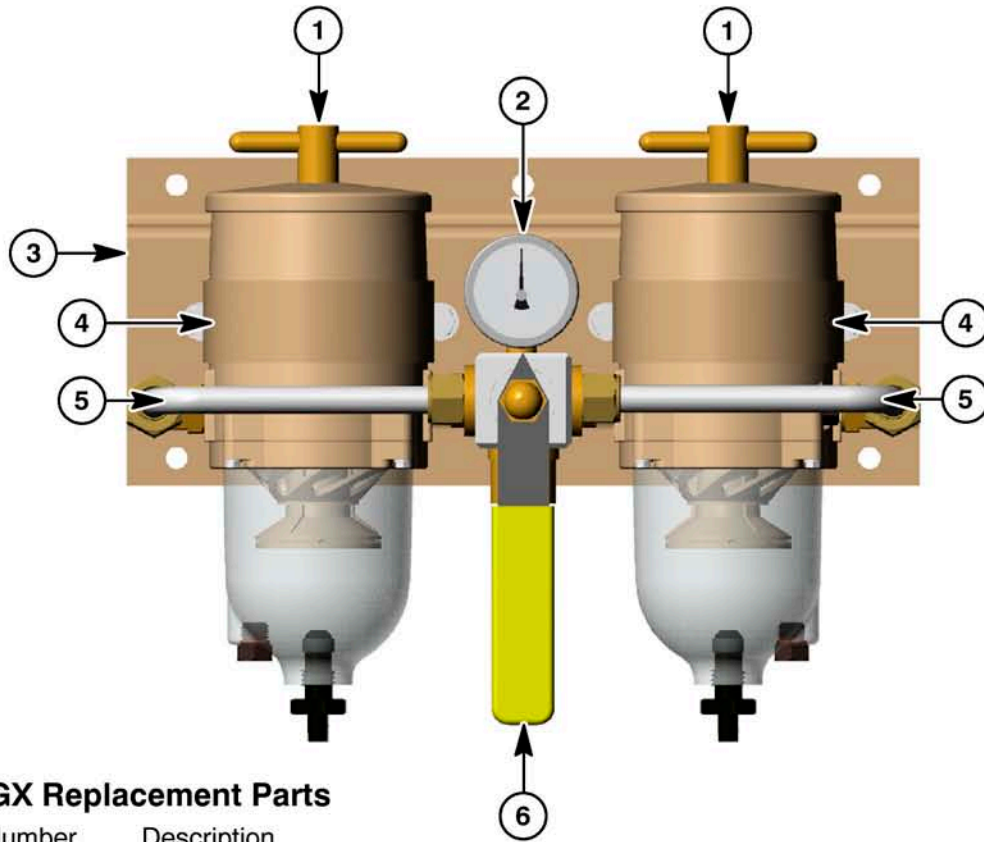

**75500FGX Replacement Parts**

<u>Part Number</u>	<u>Description</u>
1 <b>500FG</b>	See 500FG Replacement Parts List
2 <b>RK19476</b>	Gauge Assembly Kit
3 <b>RK15329</b>	Main Bracket Kit
4 <b>RK15378</b> <b>RK11838</b>	Housing Bracket Housing Bracket Hardware (5/16"-18, not shown)
5 <b>RK15344</b>	Rigid Tubing and Fittings Kit
6 <b>RK15321</b> <b>RK15389</b>	Valve Assembly Kit Valve Service Kit (not shown)

**Performance Data** (Controlled laboratory tests. Field results may vary.)  
 (PSI X 2.036 = inHg) (PSI X 6.895 = kPa)

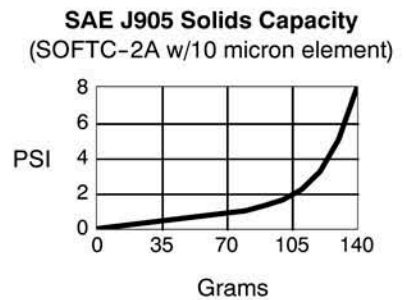
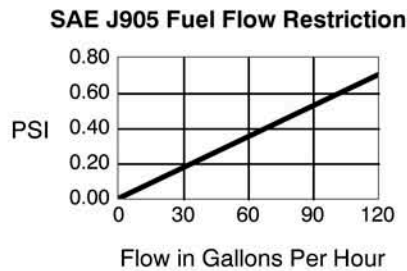
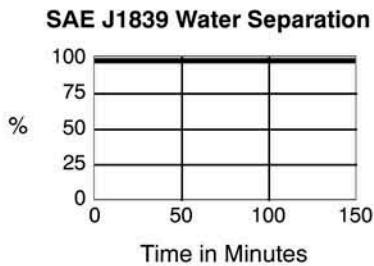

## How To Order (The example below illustrates how part numbers are constructed.)

<b>75900FHX</b>	<b>312</b>	<b>2</b>
Base model with 7/8"-14 UNF fuel ports (SAE J514).	Add '312' for a 12 volt dc heater <u>or</u> '324' for a 24 volt dc heater <sup>†</sup> . (omit if not desired)	Specify a micron rating: '2', '10', <u>or</u> '30'.
† 300 watt heater, recommended for use with a Racor relay kit. See Accessories.		

Replacement Elements (seals included)		
<b>2 Micron</b> (Final Filtration)	<b>10 Micron</b> (Secondary Filtration)	<b>30 Micron</b> (Primary Filtration)
<b>2040SM-OR</b>	<b>2040TM-OR</b>	<b>2040PM-OR</b>
<b>Note:</b> 75900FHX assemblies use TWO elements (one per 900FH housing).		

## Mounting Instructions

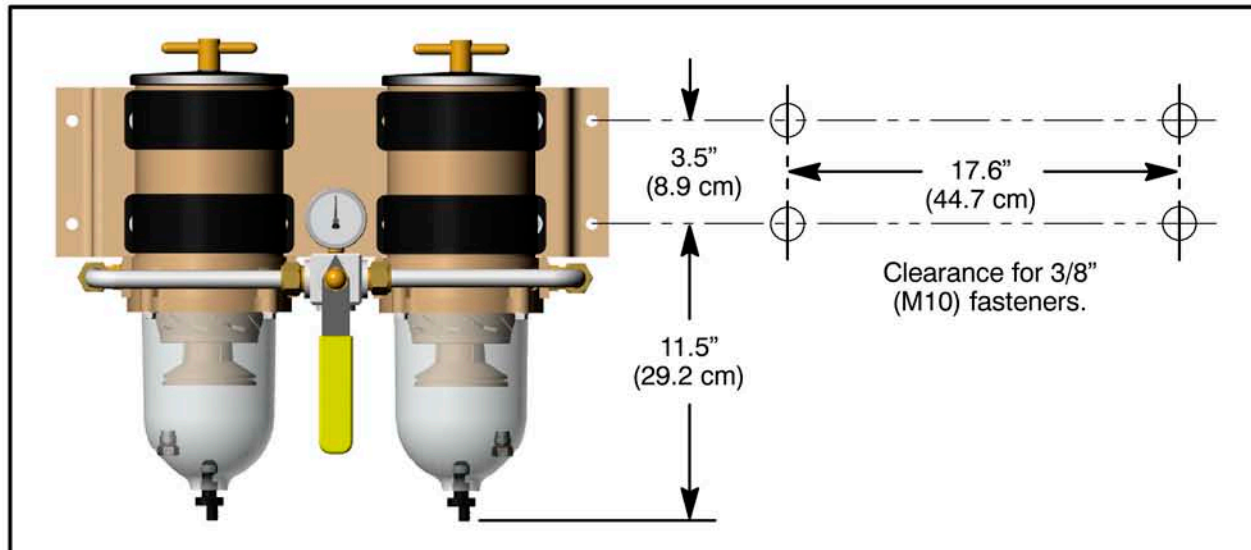

**Notes:** Mount filter assembly as close to vertical (V) as possible. For best efficiency, do not exceed 10° from vertical.

Do not remove valve fittings as they are integral components to the valve body.

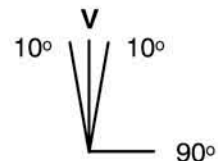

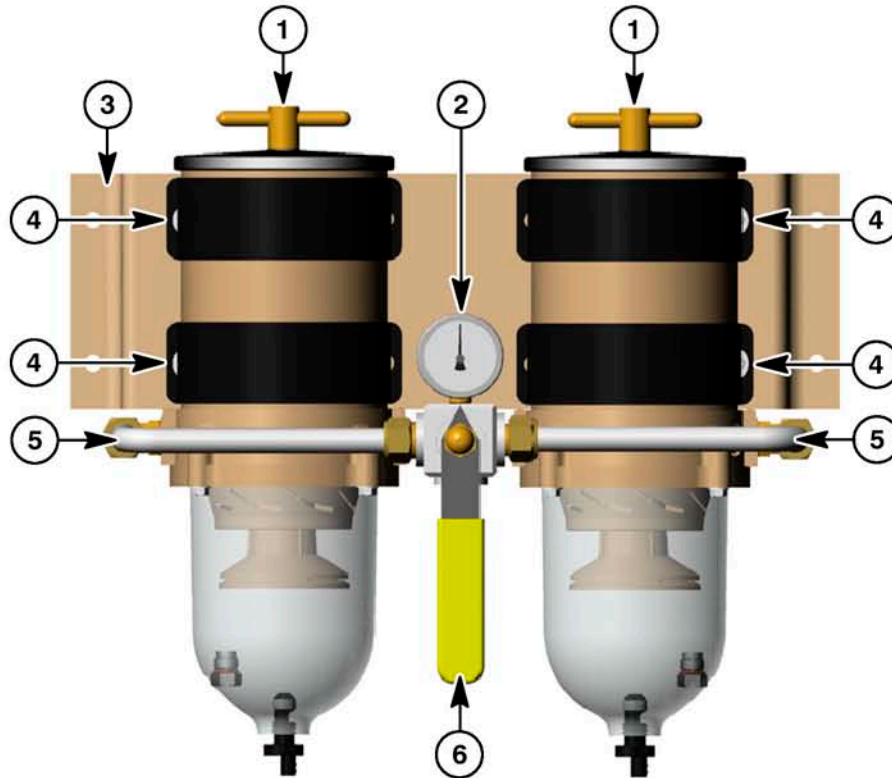

**75900FHX Replacement Parts**

Part Number	Description
1 <b>900FH</b>	See 900FH Replacement Parts List
2 <b>RK19476</b>	Gauge Assembly Kit
3 <b>RK19486</b>	Main Bracket Kit
4 <b>RK11815-103</b>	Housing Bracket (Includes Hardware)
5 <b>RK19475</b>	Rigid Tubing and Fittings Kit
6 <b>RK19473</b> <b>RK19506</b>	Valve Assembly Kit Valve Service Kit (not shown)

**Performance Data** (Controlled laboratory tests. Field results may vary.)  
 (PSI X 2.036 = inHg) (PSI X 6.895 = kPa)

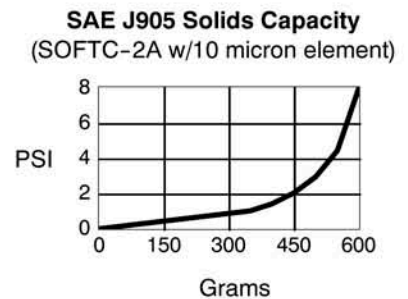
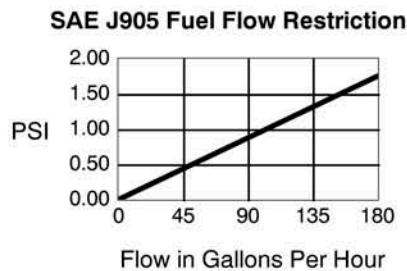
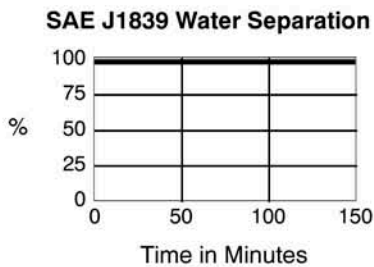

**How To Order** (The example below illustrates how part numbers are constructed.)

<b>751000FHX</b>	<b>312</b>	<b>2</b>
Base model with 7/8"-14 UNF fuel ports (SAE J514).	Add '312' for a 12 volt dc heater or '324' for a 24 volt dc heater <sup>1</sup> . (omit if not desired)	Specify a micron rating: '2', '10', or '30'.
<sup>1</sup> 300 watt heater, recommended for use with a Racor relay kit. See Accessories.		

<b>Replacement Elements</b> (seals included)		
<b>2 Micron</b> (Final Filtration)	<b>10 Micron</b> (Secondary Filtration)	<b>30 Micron</b> (Primary Filtration)
<b>2020SM-OR</b>	<b>2020TM-OR</b>	<b>2020PM-OR</b>
<b>Note:</b> 751000FHX assemblies use TWO elements (one per 1000FH housing).		

**Mounting Instructions**

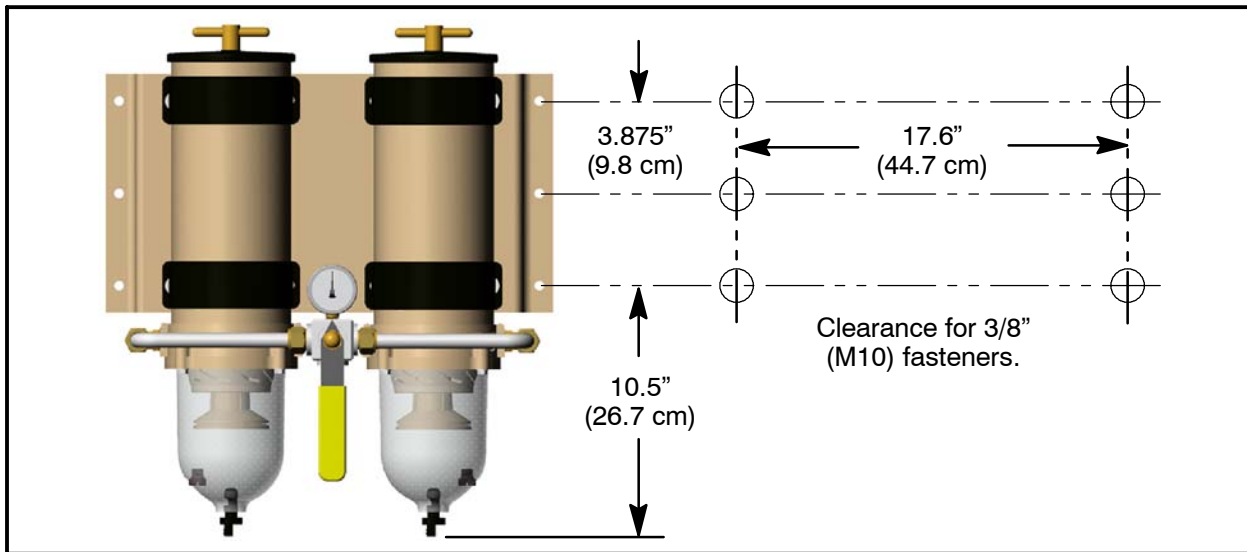

**Notes:** Mount filter assembly as close to vertical (**V**) as possible. For best efficiency, do not exceed 10° from vertical.

Do not remove valve fittings as they are integral components to the valve body.

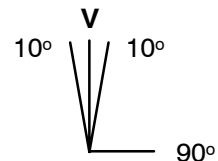

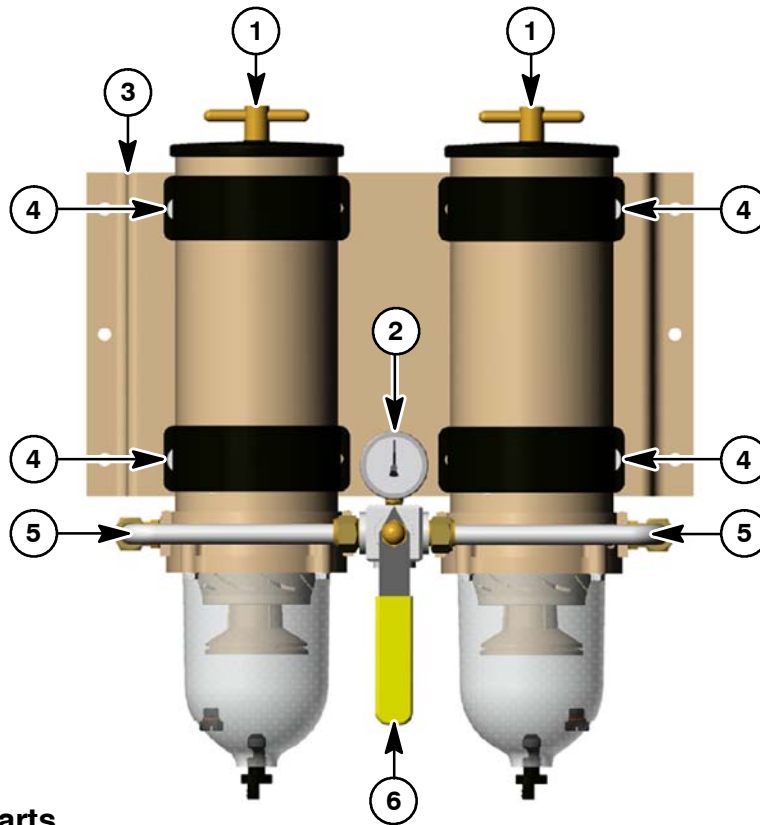

**751000FHX  
Replacement Parts**

<u>Part Number</u>	<u>Description</u>
1 <b>1000FH</b>	See 1000FH Replacement Parts List
2 <b>RK19476</b>	Gauge Assembly Kit
3 <b>RK11-1777</b>	Main Bracket Kit
4 <b>RK11815-103</b>	Housing Bracket (Includes Hardware)
5 <b>RK19475</b>	Rigid Tubing and Fittings Kit
6 <b>RK19473</b>	Valve Assembly Kit
<b>RK19506</b>	Valve Service Kit (not shown)

**Performance Data** (Controlled laboratory tests. Field results may vary.)  
 (PSI X 2.036 = inHg) (PSI X 6.895 = kPa)

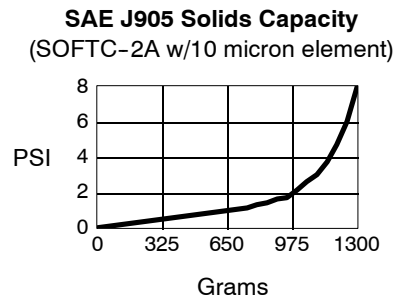
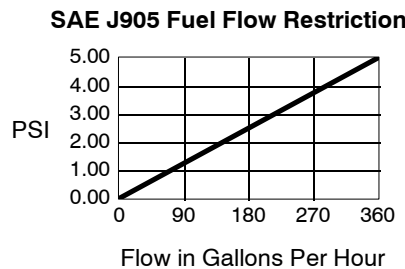
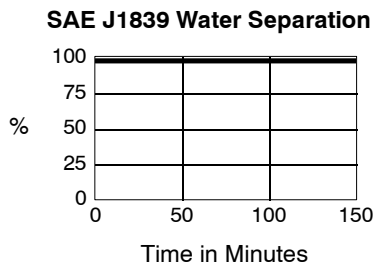

**Racor Technical Support:**  
 1-800-344-3286 ext. 7555  
 racortech@parker.com



**Notes**

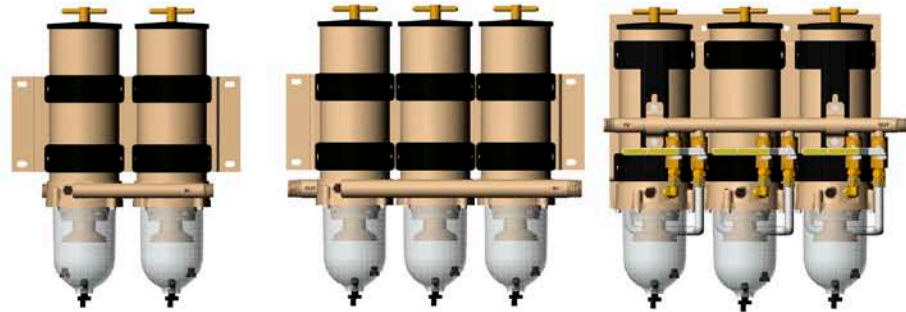

## Specifications

Basic Models	731000FH	771000FH	791000FHV
<b>Maximum Flow Rate:</b> (one unit online) (two units online) (three units online)	N/A 360 GPH (1363 LPH) N/A	N/A N/A 540 GPH (2044 LPH)	180 GPH (681 LPH) 360 GPH (1363 LPH) 540 GPH (2044 LPH)
<b>Port Size</b> (male threads)	3/4"-14 NPT (SAE J476)	1"-11.5 NPT (SAE J476)	3/4"-14 NPT (SAE J476)
<b>Min. Service Clearance</b> (above assembly) (below assembly)	10.0 in. (25.4 cm) 2.0 in. (5.1 cm)	10.0 in. (25.4 cm) 2.0 in. (5.1 cm)	10.0 in. (25.4 cm) 2.0 in. (5.1 cm)
<b>Replacement Element:</b> (2 micron) (10 micron) (30 micron)	(2 Per Assembly) 2020SM-OR 2020TM-OR 2020PM-OR	(3 Per Assembly) 2020SM-OR 2020TM-OR 2020PM-OR	(3 Per Assembly) 2020SM-OR 2020TM-OR 2020PM-OR
<b>Height</b>	22.0 in. (55.9 cm)	22.0 in. (55.9 cm)	22.0 in. (55.9 cm)
<b>Depth</b>	12.0 in. (30.5 cm)	12.0 in. (30.5 cm)	11.8 in. (30.0 cm)
<b>Width</b>	16.5 in. (41.9 cm)	21.5 in. (54.6 cm)	21.5 in. (54.6 cm)
<b>Weight</b> (dry)	26.0 lb (11.8 kg)	39.0 lb (17.7 kg)	52.0 lb (23.6 kg)
<b>Clean Pressure Drop</b>	1.7 PSI (11.7 kPa)	1.7 PSI (11.7 kPa)	2.5 PSI (17.2 kPa)
<b>Maximum Pressure</b> <sup>1</sup>	15 PSI (1 bar)	15 PSI (1 bar)	15 PSI (1 bar)
<b>Water In Bowl Capacity</b> (per bowl)	10.3 oz (305 ml)	10.3 oz (305 ml)	10.3 oz (305 ml)
<b>Available Options:</b> <sup>2</sup> (water detection kit) (12 or 24 vdc heater) (vacuum gauge)	Yes Yes Yes	Yes Yes Yes	Yes Yes Yes
<b>Operating Temperature</b>	-40° to +255°F / -40° to +121°C		

<sup>1</sup> Pressure installations are applicable up to the maximum PSI shown. Vacuum installations are recommended.

<sup>2</sup> Not for use on gasoline applications.

**How To Order** (The example below illustrates how part numbers are constructed.)

<b>731000FH</b>	<b>312</b>	<b>2</b>
Base model with 7/8"-14 UNF fuel ports (SAE J514).	Add '312' for a 12 volt dc heater or '324' for a 24 volt dc heater <sup>†</sup> . (omit if not desired)	Specify a micron rating: '2', '10', or '30'.
† 300 watt heater, recommended for use with a Racor relay kit. See Accessories.		

<b>Replacement Elements</b> (seals included)		
<b>2 Micron</b> (Final Filtration)	<b>10 Micron</b> (Secondary Filtration)	<b>30 Micron</b> (Primary Filtration)
<b>2020SM-OR</b>	<b>2020TM-OR</b>	<b>2020PM-OR</b>
<b>Note:</b> 731000FH assemblies use TWO elements (one per 1000FH housing).		

**Mounting Instructions**

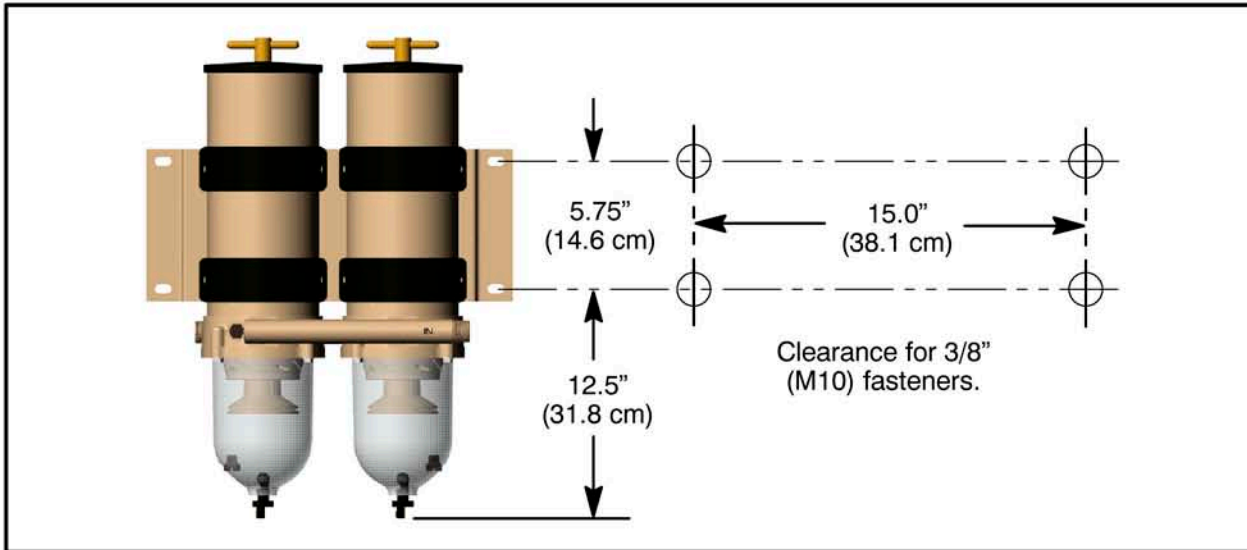

**Note:** Mount filter assembly as close to vertical (V) as possible. For best efficiency, do not exceed 10° from vertical.

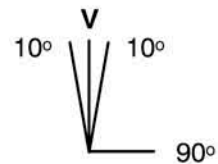

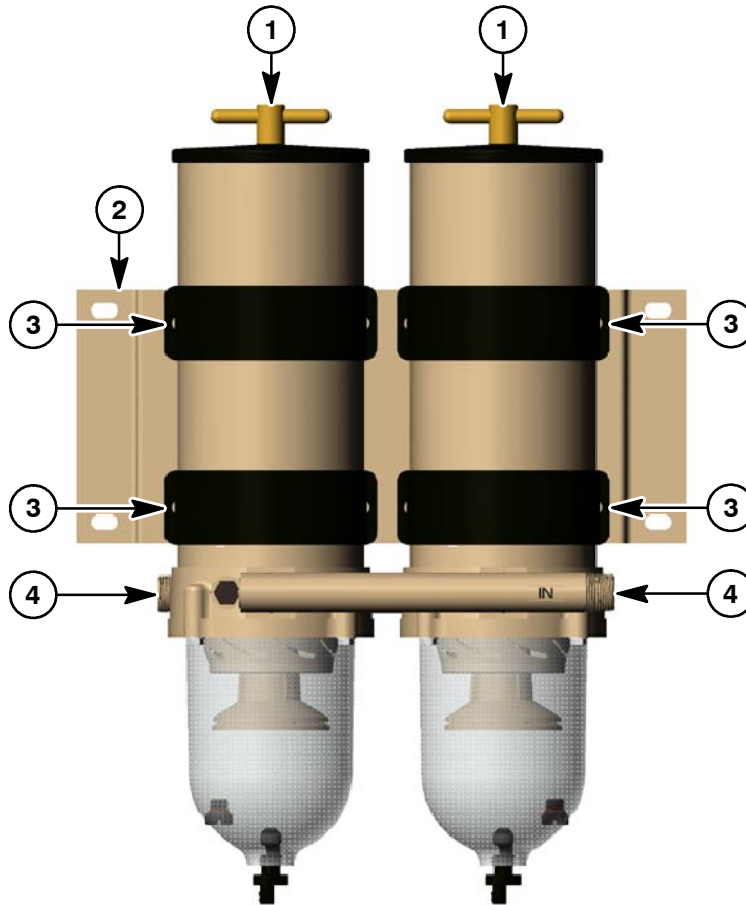

**731000FH Replacement Parts**

<u>Part Number</u>	<u>Description</u>
1 <b>1000FH</b>	See 1000FH Replacement Parts List
2 <b>11065</b>	Main Bracket Kit
3 <b>RK11815-103</b>	Housing Bracket (Includes Hardware)
4 <b>RK11892</b>	Inlet or Outlet Mainfold Tube (with 3/4"-16 NPT Threads)

**Performance Data** (Controlled laboratory tests. Field results may vary.)  
 (PSI X 2.036 = inHg) (PSI X 6.895 = kPa)

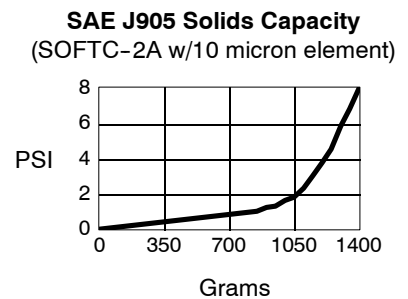
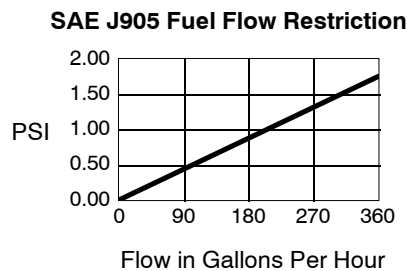
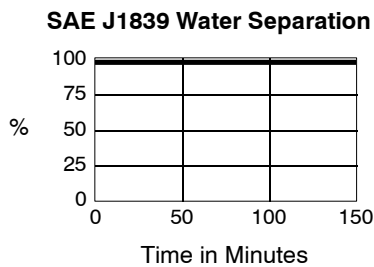

**How To Order** (The example below illustrates how part numbers are constructed.)

<b>771000FH</b>	<b>312</b>	<b>2</b>
Base model with 1"-11 1/2 NPT fuel ports (SAE J476).	Add '312' for a 12 volt dc heater or '324' for a 24 volt dc heater <sup>†</sup> . (omit if not desired)	Specify a micron rating: '2', '10', or '30'.
† 300 watt heater, recommended for use with a Racor relay kit. See Accessories.		

<b>Replacement Elements</b> (seals included)		
<b>2 Micron</b> (Final Filtration)	<b>10 Micron</b> (Secondary Filtration)	<b>30 Micron</b> (Primary Filtration)
<b>2020SM-OR</b>	<b>2020TM-OR</b>	<b>2020PM-OR</b>
<b>Note:</b> 771000FH assemblies use THREE elements (one per 1000FH housing).		

**Mounting Instructions**

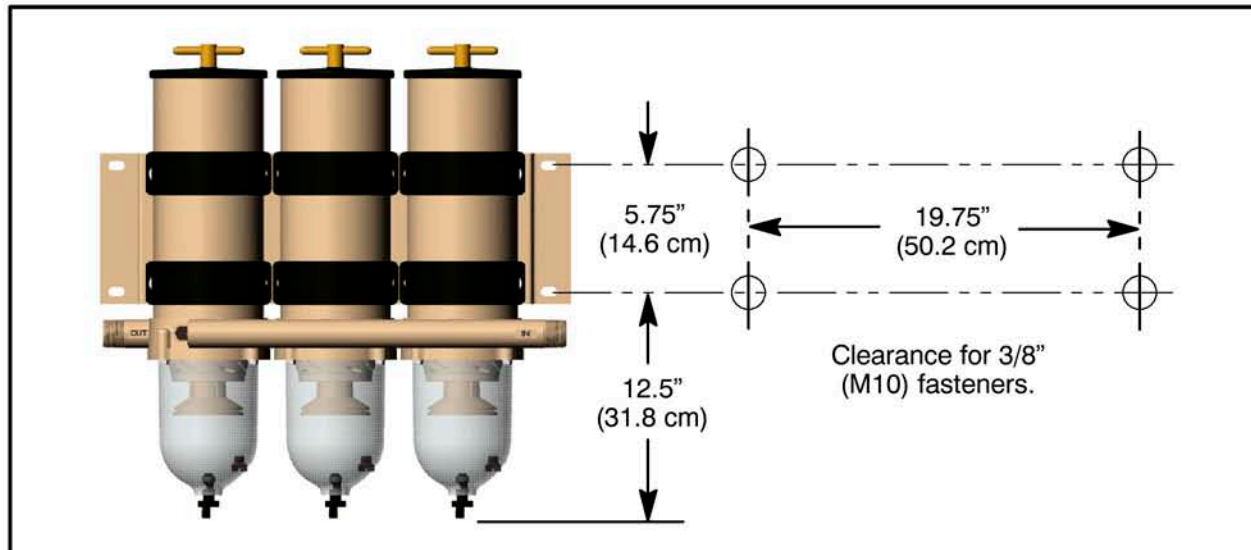

**Note:** Mount filter assembly as close to vertical (V) as possible. For best efficiency, do not exceed 10° from vertical.

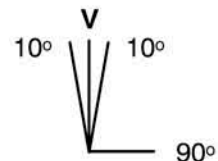

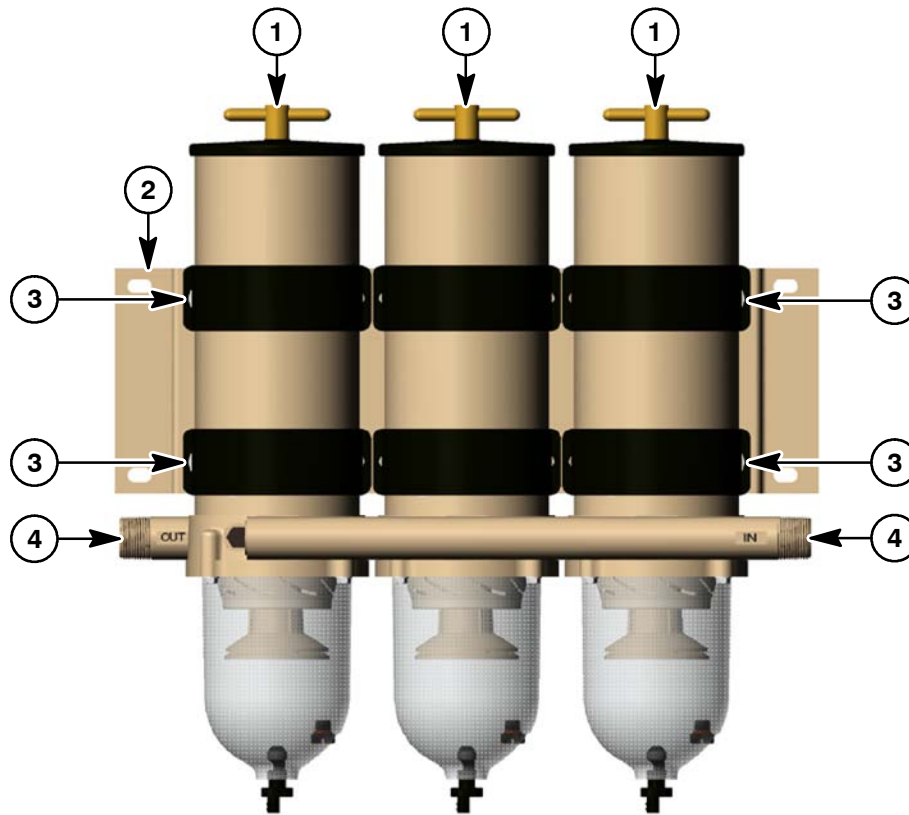

**771000FH Replacement Parts**

	<u>Part Number</u>	<u>Description</u>
1	<b>1000FH</b>	See 1000FH Replacement Parts List
2	<b>18998</b>	Main Bracket Kit
3	<b>RK11815-103</b>	Housing Bracket (Includes Hardware)
4	<b>11076</b>	Inlet or Outlet Manifold Tube (with 1"-11 1/2 NPT Threads)

**Performance Data** (Controlled laboratory tests. Field results may vary.)  
 (PSI X 2.036 = inHg) (PSI X 6.895 = kPa)

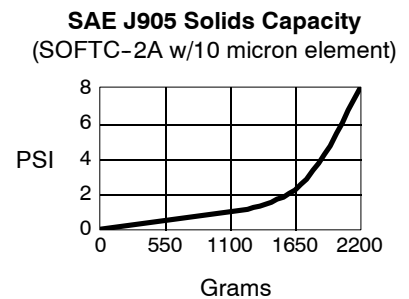
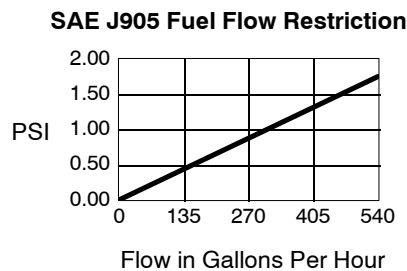
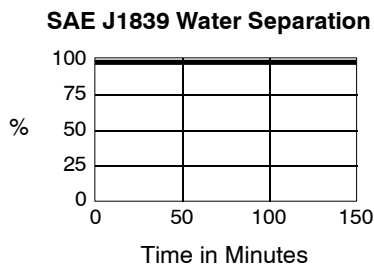

**How To Order** (The example below illustrates how part numbers are constructed.)

<b>791000FHV</b>	<b>312</b>	<b>2</b>
Base model with 3/4"-14 NPT fuel ports (SAE J476).	Add '312' for a 12 volt dc heater or '324' for a 24 volt dc heater <sup>1</sup> . (omit if not desired)	Specify a micron rating: '2', '10', or '30'.
<sup>1</sup> 300 watt heater, recommended for use with a Racor relay kit. See Accessories.		

<b>Replacement Elements</b> (seals included)		
<b>2 Micron</b> (Final Filtration)	<b>10 Micron</b> (Secondary Filtration)	<b>30 Micron</b> (Primary Filtration)
<b>2020SM-OR</b>	<b>2020TM-OR</b>	<b>2020PM-OR</b>
<b>Note:</b> 791000FHV assemblies use THREE elements (one per 1000FH housing).		

**Mounting Instructions**

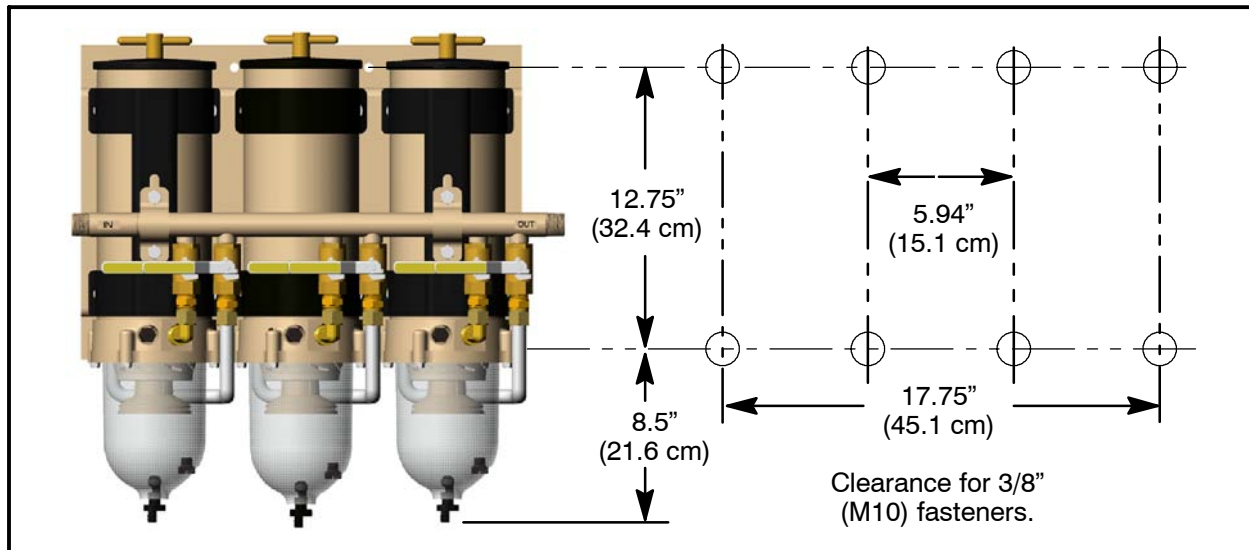

**Note:** Mount filter assembly as close to vertical (V) as possible. For best efficiency, do not exceed 10° from vertical.

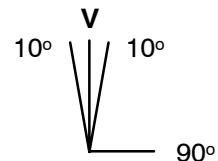

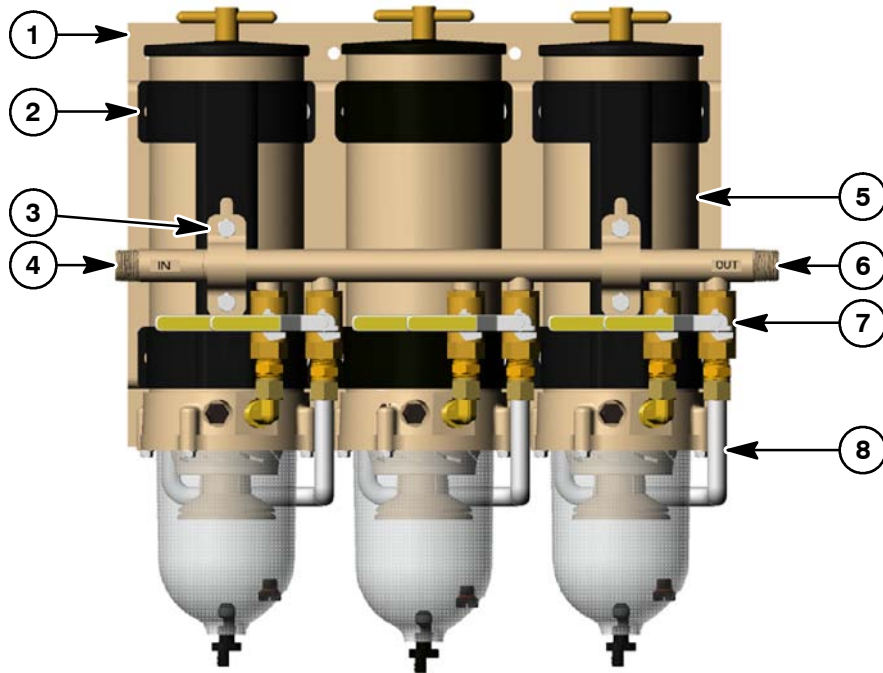

**791000FHV  
Replacement Parts**

	<u>Part Number</u>	<u>Description</u>
1	<b>11-1632</b>	Main Bracket Kit
2	<b>11895</b>	Clamp Bracket Kit
3	<b>11-1761</b>	'U' Bracket Kit
4	<b>19460</b>	Inlet Manifold Kit
5	<b>1000FH</b>	See 1000FH Replacement Parts List
6	<b>19461</b>	Outlet Manifold Kit
7	<b>RK11073</b>	1/2" Ball Valve Kit
8	<b>11-1626</b>	Formed Tubing Kit

**Performance Data** (Controlled laboratory tests. Field results may vary.)  
 (PSI X 2.036 = inHg) (PSI X 6.895 = kPa)

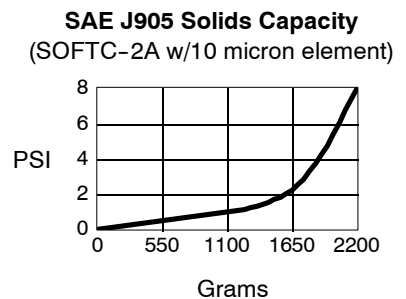
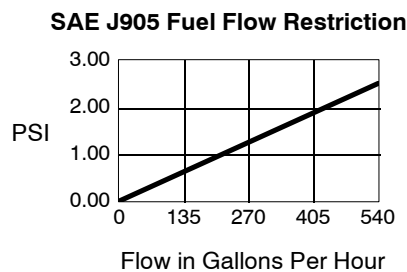
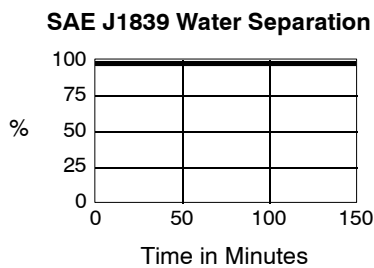

## Troubleshooting

**Note:** Correct external fuel leaks immediately! These conditions will result in reduced engine performance such as: hard starting, stalling, reduced power and fire hazards.

New filter installations must be filled with fuel and the fuel system must be adequately primed following the **engine manufacturer's recommendations**, if applicable. Existing installation difficulties are usually associated with improper priming procedures or damage to the unit or fuel system. The result is either internal air suction or external fuel leakage. Diagnose with the following steps:

1. Check fuel tank level and verify fuel delivery valves are open, if applicable.
2. Verify T-handle, bowl fasteners and fuel fittings are tight and bowl drain is closed.
3. If element is new, check potential restriction at fuel tank draw tube. An in-tank strainer may be plugged.
4. Review instructions below to uncover other solutions.

**Correct Application:** It is very important that Turbine Series filter assemblies are not 'under specified' for the application. The maximum fuel flow rating of the filter assembly must not be exceeded; doing so will reduce efficiency and de-gas (pull air from) the fuel.

**Filter Elements:** Replacement elements are available in 2, 10 and 30 micron ratings (nominal). Filtration needs are based on application, fuel quality, maintenance schedules and operating climates. A simple rule to remember is...the finer the filtration, the more frequent the filter change. **Always carry extra replacement elements with your equipment as one tankful of excessively contaminated fuel can plug an element.** When clogged to maximum capacity, elements will have a brown to black color or tar like contaminants may be present - this is normal. An appearance of a multi-colored slime (which may have a foul odor) is an indication of microbiological contamination. This condition must be treated immediately. Racor offers a wide variety of gasoline and diesel additives to prevent and treat these problems; see 'Additives' section of this catalog. Severe conditions must be corrected by a repair facility. **Note: Never operate a filter assembly without the element in place.** The element safety valve on the fuel return tube will not expose the outlet hole if the element is removed. Instead, punch the emergency tab on the top of the element and leave in place. **Warning:** Puncturing the emergency tab will bypass all filtration and send unfiltered fuel to your engine. Service the element as soon as possible to avoid harmful contaminants flowing downstream to the engine.

**Water Sensors:** This feature alerts the operator of a high-water condition. The bowl must be drained of water at the earliest convenience. **Note:** A Racor water detection module is needed to work with the in-bowl sensor. The unit should activate when the water reaches the sensor tips (and when they measure below 47,000 or 100,000 ohms of resistance, depending on the detection module used). If not, the tips may be fouled with a coating. Remove the sensor and clean the tips with a cloth. Run a jumper wire between the tips with the ignition ON to test the system. Difficulties usually lie in the wire connections, power source, or an independent ground.

**Heaters:** In-filter heaters are starting aids only, but may be left on during cold operations to supply additional heat. The 150 and 300 watt heaters are an extremely reliable option, but **MUST** be powered via a relay switch due to the initial amperage surge at start-up: 25 amps at 12 vdc and 12.5 amps at 24 vdc. They do not activate unless the fuel is below 50°F (10°C) and automatically deactivate at 80°F (28°C). **Heater Testing:** The heater can only be tested when the thermostat is closed (fuel temperature is below 50°F or 10°C). With a voltmeter attached to external wiring, and engine off, power should drop when heater is switched on. (Option - remove the heater and place in a freezer until the temperature is under 50°F (10°C). Remove the heater and repeat the above test).

## Troubleshooting

**All Racor Turbine Series filter assemblies are 100% tested to ensure a leak-proof, quality product.**

**Note:** Correct external fuel leaks immediately! In the event difficulties are experienced with your filter assembly or a problem appears to prevent the engine from running smoothly, follow the quick-help illustration below or refer to the procedures on the previous page. Apply Parker Super O-lube (part number RK31605) or equivalent to all seals at major attachment points to maintain integrity, seal elasticity, to fill small voids and provide protection from degradation.

**Perform the following checks with the engine OFF (and applicable valves closed). For replacement parts, refer to the appropriate 'Replacement Parts' section of this catalog.**

**Damaged, worn, or dirty seals will allow air ingestion. Inspect and replace all seals as needed. Lube all seals with Parker Super O-lube. Clean sealing surfaces of dirt or debris every time element is replaced.**

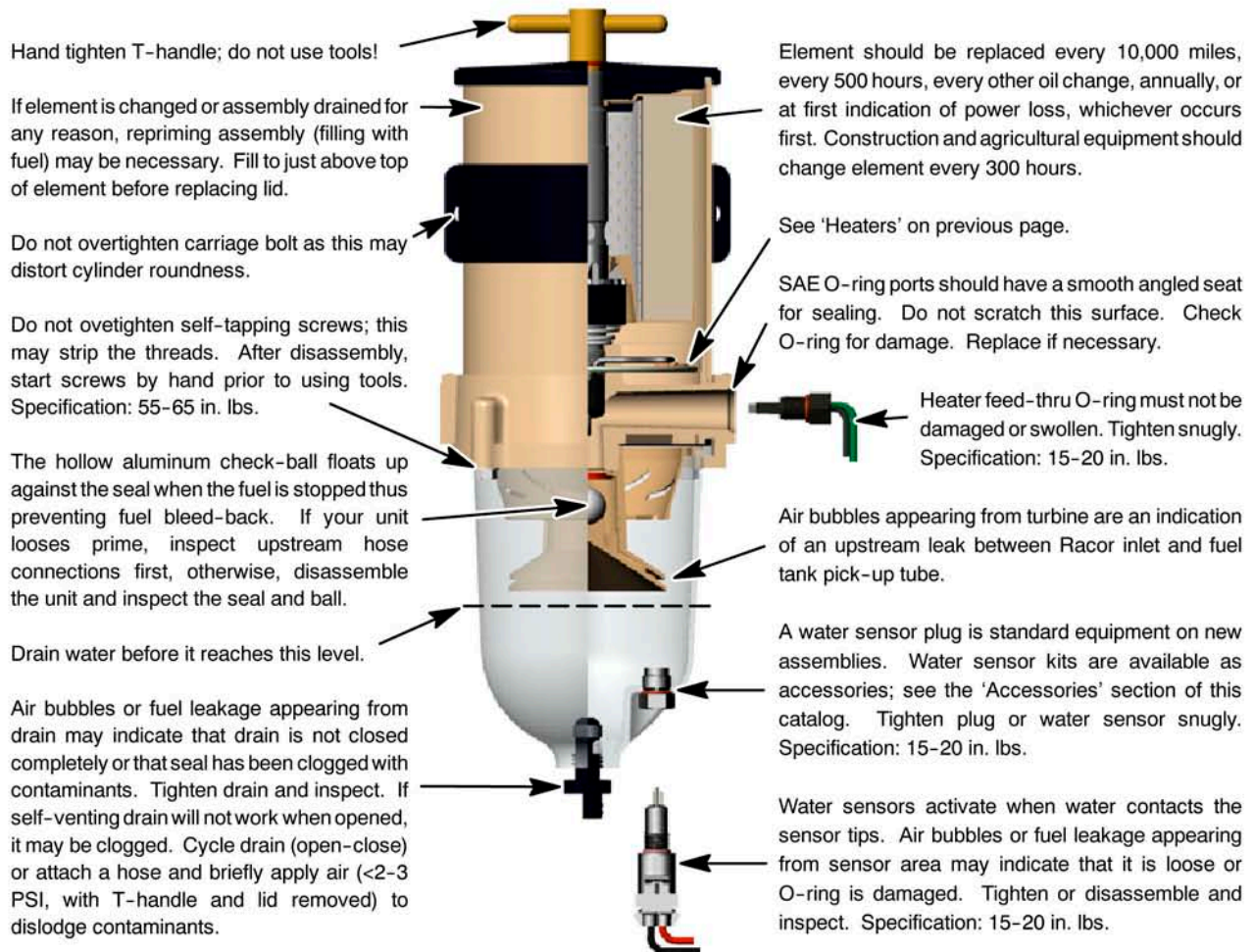

**Notes**