

Fuel Filtration Products

- Diesel
- Gasoline
- Alternative Fuels
- Aviation Fuels





For over thirty years, there has been one brand of fuel filtration systems that has earned the confidence and respect of engine and equipment builders, owners and operators around the world – Racor.

Leading edge technology and continuous innovation are designed into every system and genuine Aquabloc II filter elements have set the global standard. In every configuration, at every flow rate and in any operating environment, Racor is the most trusted name in engine protection. Why trust your investment to anything less?



FUEL



1969
It all began with a patented, exceptionally efficient fuel filter/water separator. Today, the Racor Turbine Series remains the preferred choice on land and sea.



1995
Today's alternative fuels are susceptible to the problems that result from water and solid contamination. Racor alternative energy filtration systems provide the solution.



1983
Aquabloc II® filters debut, and Racor Filter/ Separators make another significant leap in filtration efficiency.



1987
With see-thru bowls or UL-listed, USCG accepted metal bowls, Racor's diesel and gasoline filter/separators introduced convenience, reliability and peace-of-mind in one easy spin.

1997
High-flow hydrocarbon vessels are manufactured to ASME standards and filters meet API/IP and military qualifications.



1991
Racor makes a commitment to the environment with Lifeguard, a fuel/air separator that prevents fuel from escaping overboard from vent lines during refueling.



2002
The Racor Fuel Conditioning Module delivers consistent fuel pressure and volume to high pressure fuel injection systems under various speeds, loads and environmental conditions.



OIL



1992
 Revolutionary, permanent full-flow oil filtration systems put an end to messy filter changes and expensive disposal. These remote mounts can be combined with Racor bypass oil filters and oil analysis to significantly extend oil changes.



1995
 The Racor spin-on oil solution is ingenious and offers a permanent cleanable system that puts an end to frequent and messy on-board filter changes.



2001
 The LFS300 Series converts a standard disposable spin-on can to a premium cartridge oil filter that's crushable, burnable and increases capacity and efficiency.



AIR

1994
 Engines gasping for a breath of fresh air breathe easy with the introduction of heavy-duty air filters.

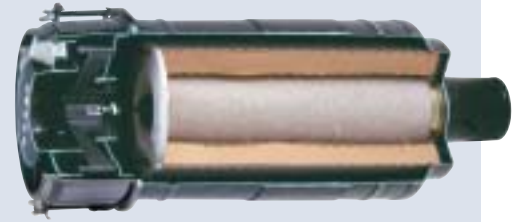

1995
 Crankcase ventilation filter systems that keep oily blowby from coating turbochargers and precision components are introduced. While cleaning up engine compartments, Racor CCV™ systems meet new environmental regulations to control crankcase emissions.



1999
 Racor debuts its own marine air intake filters to provide clean intake air and reduce turbo noise.



2002
 High performance lightweight air filters protect engines from damaging contamination. A large media area reduces air flow resistance and provides higher dirt-holding capacity.

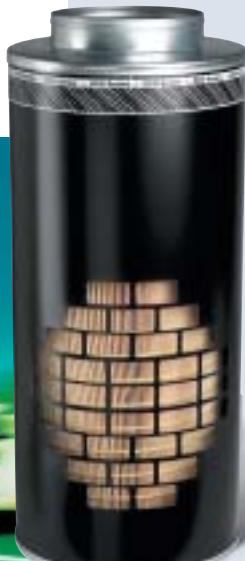

COOLANT

HYDRAULIC



1993
Racor pioneers the use of coolant heating to improve fuel filtration and engine operation in winter.

1995
Racor additives help clean up coolant and fuel systems with ultra-high performance, ultra-concentrated additives. It's Racor protection in a bottle.



2001
The comprehensive fuel heating series expands with tank-type coolant heaters, as well as powerful self-regulating electric heaters... all designed to help you turn your back on old man winter.

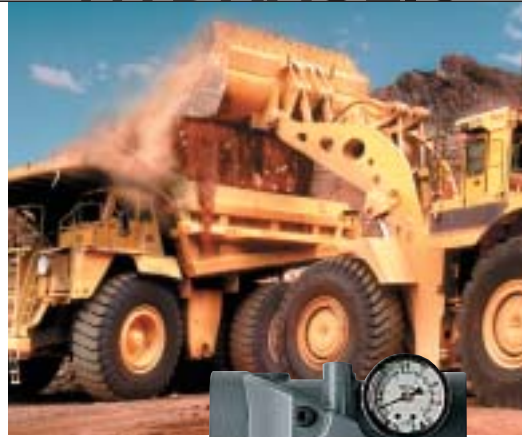

1994
Racor engineers turn their attention to hydraulic systems and respond with innovative water-absorbing media that self-regulates its performance... swelling as it reaches capacity.



1996
Medium pressure hydraulic filters expand Racor's commitment to ultimate filtration for every engine, every system, every flow rate.



- P Series 2-3
- In-Line Fuel Filtration 4
- Diesel Spin-On Series 5-7
- High-Capacity Fuel Filtration 8-9
- Turbine Series 10-11
- Fuel Dispensing 12-13
- Alternative Fuels 14-15
- Engine Coolant Heating System 16
- Electric Heaters 17
- Additives 18-19
- Gauges 20-21
- Racor System Solutions 22
- More From Racor 23-25





The Racor fuel conditioning module is designed and manufactured to provide the highest possible value to the diesel engine, vehicle and equipment. The innovation and modular design of the RFCM incorporates all of the low pressure fuel components required by the latest generation of electronically-controlled fuel injection systems. The consistent pressure and volume delivery of pure fuel under various engine speeds, loads and environmental conditions is absolutely essential to achieve the efficiency levels required in today's engines. The modular design of the RFCM allows features to be added or removed independent of one another – providing a new level of design flexibility.



Robust roller-cell electric fuel pump ensures consistent fuel delivery at a variety of engine speeds.

Thermostatically (10°C / 50°F – 26°C / 80°F) controlled PTC style electric fuel heater (200 watts at 12V DC) facilitates cold weather starting.

Thermal recirculation valve regulates return fuel recirculation for optimum performance during cold weather operation (10°C / 50°F – 32°C / 90°F).

The patented RFCM contains Racor's high performance Aquabloc II filter media.

Environmentally friendly cartridge-style element is incinerable and is available at the required efficiency levels for high pressure diesel fuel injection systems. An anti-drainback valve makes element service convenient and clean.

Contaminant collection bowl is removable.

Water sensing system alerts the operator when service is required and a self-venting drain valve makes draining quick and easy.

Also available in see-thru collection bowl.



Durable, 12V DC roller-cell electric fuel pump offers the benefit of an electric, on-demand, priming pump.

Thermostatically controlled PTC style electric (150-watt) heater facilitates cold weather starting.

High performance Aquabloc II cartridge-style filter media is environmentally friendly and incinerable.

Water-in-fuel (WIF) sensor alerts the operator when service is required. Under-dash control module for pump and water sensor operation is included with pump option.

Contaminant collection bowl with self-venting drain is both removable and reusable.

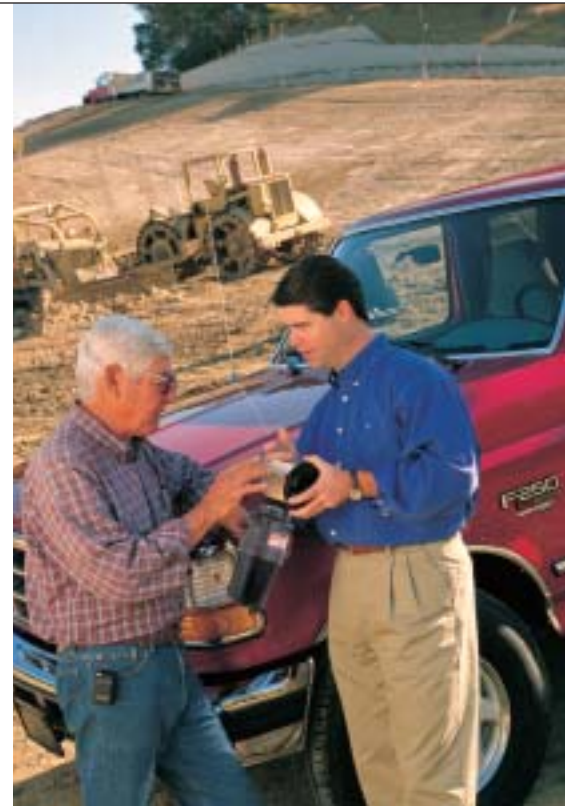

| Basic Models | P3 | P4 | P5 |
|-------------------------------------|---------------------------------|-------------------|-------------------|
| Maximum Flow Rate | 30 gph / 114 lph | 40 gph / 170 lph | 50 gph / 227 lph |
| Clean Pressure Drop | 0.4 psi / 2.8 kPa | 0.5 psi / 3.4 kPa | 0.8 psi / 5.5 kPa |
| Maximum Pump Output (at 14.4 volts) | 40 gph / 151 lph | 40 gph / 151 lph | 40 gph / 151 lph |
| Standard Fuel Port Size (SAE J476) | 3/8" - 18 npt | 3/8" - 18 npt | 3/8" - 18 npt |
| Total Number of Ports Available: | 2 | 2 | 2 |
| Fuel Inlets | 1 | 1 | 1 |
| Fuel Outlets | 1 | 1 | 1 |
| Replacement Elements: | | | |
| 02 micron | R58060-02 | R58095-02 | R58039-02 |
| 10 micron | R58060-10 | R58095-10 | R58039-10 |
| 30 micron | R58060-30 | R58095-30 | R58039-30 |
| Minimum Service Clearance | 2.5" (28 mm) | 2.5" (28 mm) | 2.5" (28 mm) |
| Height | 7.7" (196mm) | 9.0" (229 mm) | 11.5" (292 mm) |
| Depth | 5.2" (132 mm) | 5.2" (132 mm) | 5.2" (132 mm) |
| Width | 4.8" (122 mm) | 4.8" (122 mm) | 4.8" (122 mm) |
| Weight (dry) | 3.4 lb (1.5 kg) | 3.8 lb (1.7 kg) | 4.2 lb (1.9 kg) |
| Maximum Pump Output Pressure | 10 psi (69 kPa) | 10 psi (69 kPa) | 10 psi (69 kPa) |
| Features: ¹ | | | |
| Water Sensor | Standard | Standard | Standard |
| Heater | Standard | Standard | Standard |
| Pressure Regulator (10 psi) | Standard | Standard | Standard |
| Operating Temperature | -40° to +255°F / -40° to +121°C | | |

Vacuum installations are recommended. ¹Not for use with gasoline applications.

How To Order – The example below illustrates how part numbers are constructed.

| P4 | 2 | 10 | N | H |
|--|--|---|--|--|
| Specify 'P3' for 30 gph, 'P4' for 40 gph, or 'P5' for 50 gph | '2' must be in the part number. (It specifies a 12 vdc pump) | Specify micron rating of element: '10' only | 'N' must be in the part number. (It specifies standard 3/8" npt ports) | 'H' must be in the part number. (It specifies a 12 vdc, 150 watt heater) |

For continuous run pump operation, custom fittings, or pressure requirements consult factory (1-800-344-3286).

The patented P Series diesel fuel

conditioning module (for vacuum side

applications only) was developed for

application in any diesel engine fuel

injection system. P Series assemblies are

available in three sizes and all feature

3/8" NPT fuel ports. This innovative and

modular fuel filter/water separator

incorporates low-pressure fuel system

components into a single package.

IN-LINE FUEL FILTRATION

From personal watercraft to agricultural equipment, Racor in-line filters are designed to protect fuel pumps, carburetors, injectors and related fuel system components. We offer a complete range of disposable and cleanable in-line prescreen products.



| MODEL NO. | 025-RAC-01 | 025-RAC-02 | 025-RAC-05 | 025-RAC-10 | 025-RAC-11 | 025-RAC-12 | 025-RAC-13 | 035-RAC-159 | PS120 |
|-----------------------------|------------|------------|------------|------------|------------|------------|------------|-------------|---------|
| Maximum Flow Rate | 25 gph | 25 gph | 25 gph | 50 gph | 15 gph | 15 gph | 15 gph | 25 gph | 120 gph |
| Gasoline or Diesel | both | both | both | both | both | both | both | both | both |
| Vacuum Installation | ✓ | ✓ | ✓ | ✓ | ✓ | ✓ | ✓ | ✓ | ✓ |
| Pressure Installation | No | No | No | 50 psi | No | No | No | No | Yes |
| Maximum PSI/kPa | 5 | 5 | 5 | 5 | 5 | 5 | 5 | 5 | 5 |
| Clean Pressure Drop PSI/kPa | 0.26 | 0.35 | 0.5 | 0.5 | 0.5 | 0.5 | 0.5 | 0.25 | .25 |
| No. of Ports | 2 | 2 | 2 | 2 | 2 | 2 | 2 | 2 | 2 |
| Port Size | 1/4" NPT | 1/4" NPT | 5/16" | 1/2" NPT | 1/4" BARB | 5/16" | 3/8" | 1/4" | 3/8" |
| Replacement Element No. | S2501 | S2502 | N/A | N/A | N/A | N/A | N/A | N/A | N/A |
| Height | 4.3" | 4.3" | 4.75" | 4.75" | 3.92" | 3.92" | 3.92" | 4.7" | 7.25" |
| Width | 2.25" | 2.25" | 2.30" | 4.19" | 3.92" | 3.92" | 3.92" | 3.3" | 4.0" |
| Depth | 2.10" | 2.10" | 2.30" | 1.875" | 2.0" | 2.0" | 2.0" | 3.3" | 3.0" |
| Weight | 0.3 | 0.3 | 0.1 | 0.3 | 0.25 | 0.25 | 0.25 | 0.25 | 0.75 |

The best gaskets and o-rings available promise consistent, sure seals.

Die cast aluminum heads with multiple ports make installation as easy as adding options.

Powerful primer pumps are integrated into mounting heads.



Aquabloc II media is corrugated, allowing greater surface area exposure for fuel filtration and an increased dirt-holding capacity.

Polymer bowls are virtually indestructible. They won't discolor from exposure to alcohol, additives or UV light – a see-thru that stays see-thru. A die cast aluminum bowl is available for most models.

Water sensor and vacuum gauges to signal service are valuable options available for most models.

Bowl removal wrench available 22628



Positive seal self-venting drain eliminates leaks and speeds service.

Cost-Effective Visual Inspection

See-thru collection bowls allow a water-in-fuel condition to be immediately visible. Closed spin-on cans waste expensive fuel and labor because it's impossible to check for water without actually opening the drain or removing the can from the mounting head.

Environmentally Friendly

Engineered polymer bowls are reusable, impact-resistant and virtually indestructible. When it's time for service, only the filter element is replaced – the see-thru bowl and drain valve assembly are reused. The long life cycle of the bowl saves money and reduces the environmental impact through disposal of less material. Use metal bowl versions for inspected or commercial vessels.

Easy Upgrades

See-thru bowls provide connection ports for upgrades which enhance engine performance and reliability. Powerful in-bowl heaters can be added to improve operation in colder climates and electronic sensors alert the operator to drain water in the bowl.

Corrosion-Free Construction

Advanced polymer technology means bowls will not deteriorate from water collection, alcohol-blended fuels, exposure to harsh additives or UV light. Unseen water lying in sealed cans causes them to rust and corrode or worse yet, increase in level and pass through.

For marine rated filters see brochure #7501.

110A - 120A - 140

Maximum protection in minimum space

The 110A is designed for fuel-injected gasoline engines with high working pressures and also can be used on diesel engines. A metal housing is standard.

Other models in the 100 Series, the 120A and 140, offer reliable protection for smaller diesel and gasoline engines used in generator sets, pressure washers and other equipment. Their compact size fits tight mounting locations and multiple ports offer installation flexibility.



Model 120A



Model 230

215 - 230 - 245

Improved for greater versatility

The 215, 230 and 245 filter/separators come standard with an integral priming pump and a new see-thru contaminant bowl which can operate in applications up to 30 psi. Another design upgrade is the optional 200-watt in-bowl heater for colder operating conditions. Applications include light-duty and medium-duty trucks and vehicles, construction, agricultural and other diesel-powered equipment.

For marine rated filters see brochure #7501.



L O W F L O W

| MODEL | 110A | 120A | 140 | 215 | 230 | 245 |
|---|--|----------------------|----------------------|----------------------|----------------------|----------------------|
| Maximum Flow Rate | 15 gph / 57 lph Diesel 35 gph / 132 lph Gas | 15 gph / 57 lph | 15 gph / 57 lph | 15 gph / 57 lph | 30 gph / 114 lph | 45 gph / 170 lph |
| Gasoline or Diesel ¹ | Both | Both | Both | Diesel | Diesel | Diesel |
| Vacuum Installation | Yes | Yes | Yes | Yes | Yes | Yes |
| Pressure Installation | Yes | Yes | Yes | Yes | Yes | Yes |
| Maximum PSI ² / kPa | 100 psi / 690 kPa | 7 psi / 48 kPa | 7 psi / 48 kPa | 30 psi / 207 kPa | 30 psi / 207 kPa | 30 psi / 207 kPa |
| Clean Pressure Drop PSI/kPa | 0.15 psi 1.03 kPa | 0.15 psi 1.03 kPa | 0.01 psi 0.07 kPa | 0.12 psi 0.83 kPa | 0.31 psi 2.14 kPa | 0.61 psi 4.21 kPa |
| No. of Ports | 4 | 4 | 2 | 3 | 3 | 3 |
| Port Size | 1/4" NPT/ M14 x 1.5 | 1/4" NPT/ M14 x 1.5 | 1/4" NPT/ M14 x 1.5 | 1/4" NPT/ M14 x 1.5 | 1/4" NPT/ M14 x 1.5 | 1/4" NPT/ M14 x 1.5 |
| Integral Primer Pump ³ | No | No | No | Yes | Yes | Yes |
| Replacement Element No. ⁴ | R11 | R12 | R12 | R15 | R20 | R25 |
| Bowl/See-Thru | No | Yes | Yes | Yes | Yes | Yes |
| Bowl/Metal ¹ | STD | Yes | Yes | Yes | Yes | Yes |
| Drain Type | Positive Seal | Positive Seal | Positive Seal | Positive Seal | Positive Seal | Positive Seal |
| Water Sensor Option ⁵ | Yes | Yes | Yes | Yes | Yes | Yes |
| Electric Heater Option ⁵ (12V/24V) | No | No | No | Yes | Yes | Yes |
| Height | 6" / 152mm | 6.5" / 166mm | 6" / 152mm | 8.3" / 211mm | 9" / 229mm | 10.5" / 267mm |
| Width | 3.2" / 81mm | 3.2" / 81mm | 3.2" / 81mm | 4" / 102mm | 4" / 102mm | 4" / 102mm |
| Depth | 3.2" / 81mm | 3.2" / 81mm | 3.2" / 81mm | 4" / 102mm | 4" / 102mm | 4" / 102mm |
| Weight | 1.3 lbs / 0.59 Kg | 1.1 lbs / 0.50 Kg | 1.1 lbs / 0.50 Kg | 1.8 lbs / 0.80 Kg | 2 lbs / 0.90 Kg | 2.2 lbs / 1.0 Kg |

Notes: (1) Metal bowls should be used for gasoline installations.
 (2) Pressure installations are applicable up to the maximum PSI/kPa shown.
 (3) Models with integral primer pumps are not recommended for gasoline applications.
 (4) Replacement element micron rating can be specified as "S" for 2 micron, "T" for 10 micron, or "P" for 30 micron, except for R11.
 (5) Not for use with gasoline applications.



Model 490

445 - 460 - 490

A powerful, integral primer pump makes service quick and easy

The standard equipment primer pump tops the list of extensive options that allow bus fleets, truck fleets, RV owners and others to tailor a filter/separator system specifically to their operating requirements. These options include a choice of a three micron rating for the Aquabloc filter element, 200-watt in-bowl resistance heater, water sensor and flow rates up to 120 gph.



Model 660

645 - 660 - 690

Maximize engine protection with a low-profile, easy-to-fit filtration system

With all the features of the 400 Series, the 600 Series offers engine owners an economical system for applications where an integral primer pump is not needed. Flow rates up to 120 gph, in-bowl heater and water sensor are all available options.



M E D I U M F L O W

| MODEL | 445 | 460 | 490 | 645 | 660 | 690 |
|---|--------------------|--------------------|--------------------|---------------------|---------------------|--------------------|
| Maximum Flow Rate | 45 gph / 170 lph | 60 gph / 227 lph | 90 gph / 341 lph | 45 gph / 170 lph | 60 gph / 227 lph | 90 gph / 341 lph |
| Gasoline or Diesel | Diesel | Diesel | Diesel | Both | Both | Both |
| Vacuum Installation | Yes | Yes | Yes | Yes | Yes | Yes |
| Pressure Installation | Yes | Yes | Yes | Yes | Yes | Yes |
| Maximum PSI / kPa | 30 psi / 207 kPa | 30 psi / 207 kPa | 30 psi / 207 kPa | 30 psi / 207 kPa | 30 psi / 207 kPa | 30 psi / 207 kPa |
| Clean Pressure Drop PSI / kPa | 0.17 psi / 1.2 kPa | 0.39 psi / 2.7 kPa | 0.95 psi / 6.5 kPa | 0.01 psi / 0.07 kPa | 0.05 psi / 0.34 kPa | 0.29 psi / 2.0 kPa |
| No. of Ports | 4 | 4 | 4 | 7 | 7 | 7 |
| Port Size | 3/8" NPT / 16mm | 3/8" NPT / 16mm | 3/8" NPT / 16mm | 3/8" NPT / 16mm | 3/8" NPT / 16mm | 3/8" NPT / 16mm |
| Integral Primer Pump ² | Yes | Yes | Yes | No | No | No |
| Replacement Element No. ³ | R45 | R60 | R90 | R45 | R60 | R90 |
| Bowl / See-Thru | Yes | Yes | Yes | Yes | Yes | Yes |
| Bowl / Metal | No | No | No | No | No | No |
| Drain Type | Self-Vent | Self-Vent | Self-Vent | Self-Vent | Self-Vent | Self-Vent |
| Water Sensor Option ⁴ | Yes | Yes | Yes | Yes | Yes | Yes |
| Electric Heater Option ⁴ (12V/24V) | Yes | Yes | Yes | Yes | Yes | Yes |
| Height | 9.3" / 236mm | 11" / 279mm | 11.8" / 300mm | 8.46" / 215mm | 10.2" / 259mm | 11.2" / 284mm |
| Width | 4.5" / 114mm | 4.5" / 114mm | 4.5" / 114mm | 4.5" / 114mm | 4.5" / 114mm | 4.5" / 114mm |
| Depth | 4.8" / 121mm | 4.8" / 121mm | 4.8" / 121mm | 4.5" / 114mm | 4.5" / 114mm | 4.5" / 114mm |
| Weight | 2.5 lbs / 1.1 Kg | 2.7 lbs / 1.3 Kg | 2.9 lbs / 1.4 Kg | 2.35 lbs / 1.07 Kg | 2.58 lbs / 1.17 Kg | 2.65 lbs / 1.2 Kg |

Notes: (1) Pressure installations are applicable up to the maximum PSI/ kPa shown.
 (2) Models with integral primer pumps are not recommended for gasoline applications.
 (3) Replacement element micron rating can be specified as "S" for 2 micron, "T" for 10 micron, or "P" for 30 micron.
 (4) Not for use with gasoline applications.

4120 - 6120 - 3150 - 3250

High flow applications need not suffer with high maintenance... and Racor offers a range of ultra-high capacity, highly efficient fuel filter/water separators that also deliver spin-on convenience. As you'd expect, Aquabloc II media is standard, and all units provide flexibility in options to customize and meet specific operating conditions.



Racor Quality in One Easy Spin

- High-capacity, on-engine primary or secondary filtration
- Fits most existing mounting heads
- See-thru bowl with water sensor option
- Mounting heads available, contact Racor or your distributor

320 Engine Spin-On Series



H I G H F L O W

| MODEL | 4120 | 6120 | 3150 | 3250 |
|--|----------------------|-------------------|----------------------|----------------------|
| Maximum Flow Rate | 120 gph / 454 lph | 120 gph / 454 lph | 150 gph / 570 lph | 250 gph / 946 lph |
| Gasoline or Diesel ¹ | Diesel | Both | Diesel | Diesel |
| Vacuum Installation | Yes | Yes | Yes | Yes |
| Pressure Installation | Yes | Yes | Yes | Yes |
| Maximum PSI ² /kPa | 15 psi / 103 kPa | 15 psi / 103 kPa | 7psi / 50 kPa | 7 psi / 50 kPa |
| Clean Pressure Drop PSI | 0.85 psi | 0.35 psi | 0.68 psi | 1 psi |
| No. of Ports Port Size | 4 3/4" SAE / 18mm | 7 3/8 NPT | 2 0.875" X 14 SAE | 2 0.875" X 14 SAE |
| Integral Primer Pump ³ | Yes | No | No | No |
| Replacement Element No. ⁴ | R120 | R120 | S3238P | S3207P |
| Bowl / See-Thru | Yes | Yes | Yes | Yes |
| Bowl / Metal ¹ | No | No | Yes | Yes |
| Drain Type | Self-Vent | Self-Vent | Self-Vent | Self-Vent |
| Water Sensor Option ⁵ | Yes | Yes | Yes | Yes |
| Electric Heater Option ⁵ (12V/24V) | Yes | Yes | Yes | Yes |
| Height | 15" / 381mm | 14.12" / 359mm | 13.6" / 345mm | 17.25" / 438mm |
| Width | 4.5" / 114mm | 4.5" / 114mm | 5" / 127mm | 5" / 127mm |
| Depth | 4.8" / 121mm | 4.5" / 114mm | 5.5" / 140mm | 5.5" / 140mm |
| Weight | 3.9 lbs / 1.8 Kg | 3.9 lbs / 1.8 Kg | 3.6 lbs / 1.6 Kg | 4.6 lbs / 2.08 Kg |

| Fuel Filter/ Water Separator w/ Reusable See-Thru Bowl | Spin-On Replace- ment Element (only) | Micron Rating | | |
|--|--|------------------|-------|--------|
| B32001 | S3201 | 10 | 10.5" | 267 mm |
| <i>Application: Cummins – 90 gph / Secondary (Final)</i> | | | | |
| B32002 | S3202 | 30 | 10.5" | 267 mm |
| <i>Application: DDC – 90 gph / Primary</i> | | | | |
| B32003 | S3203 | 2 | 8.63" | 219 mm |
| <i>Applications: Caterpillar – 60 gph / Secondary (Final) IH (Navistar) – 90 gph / Secondary (Final)</i> | | | | |
| B32004 | S3204 | 30 | 7.13" | 181 mm |
| <i>Application: IH (Navistar) – 40 gph / Secondary</i> | | | | |
| B32005 | S3205 | 30 | 9.75" | 248 mm |
| <i>Application: Mack 90 gph – 90 gph / Primary</i> | | | | |
| B32006 | S3206 | 2 | 12" | 305 mm |
| <i>Application: Caterpillar – 90 gph / Secondary (Final)</i> | | | | |
| B32007 | S3207 | 10 | 13.5" | 343 mm |
| <i>Application: Cummins – 180 gph / Secondary (Final)</i> | | | | |
| B32008 | S3208 | * | 7.25" | 184 mm |
| <i>Application: Deutz, Volvo – 30 gph</i> | | | | |
| B32009 | S3209 | * | 8.63" | 219 mm |
| <i>Application: Mann, DAF – 60 gph</i> | | | | |
| B32011 | S3211 | 10 | 8.63" | 219 mm |
| <i>Application: Cummins Short – 90 gph / Secondary (Final)</i> | | | | |
| B32012 | S3212 | 30 | 7.13" | 181 mm |
| <i>Application: DDC – 90 gph / 8.2L Primary</i> | | | | |
| B32016 | S3216 | * | 5.85" | 149 mm |
| <i>Application: Deutz, Volvo Short – 20 gph</i> | | | | |

* Available in 2, 10 or 30 micron.

Notes: (1) Metal bowls should be used for gasoline installations.
 (2) Pressure installations are applicable up to the maximum PSI/ kPa shown.
 (3) Models with integral primer pumps are not recommended for gasoline applications.
 (4) Replacement element micron rating can be specified as "S" for 2 micron, "T" for 10 micron, or "P" for 30 micron.
 (5) Not for use with gasoline applications.

**The New Racor 777 Series:
Top-Load, High-Capacity, Low Maintenance**

Fleet operators can now have fuel filter/water separator systems that come standard with the most preferred features.

Rugged one-piece body with a heavy-duty mounting bracket. High-capacity Aquabloc II® filter elements are available in 2, 10 or 30 micron, and a standard restriction indicator shows when a filter element change-out is needed.

Top-load design for easy service, and an internal check valve avoids drain back during element change.

See-thru collection bowl allows visual monitor of accumulated water level and self-venting drain allows for quick maintenance; the fuel primer port is located at the top of the assembly.

Optional Heaters: 12V DC Pre-heater; Thermostatically-controlled coolant or return fuel heaters.



Proven Reliability

The Racor 424 and 525 Fuel Heater/Water Separators are designed to protect the precision components of medium-duty and heavy-duty diesel engines. The lightweight systems use engine coolant for heating fuel in colder climates, eliminating the need for more expensive, blended fuel. The multi-stage water separation process results in superior water removal efficiency.

The self-cleaning water separator screen does not require maintenance and accumulated water is easily emptied through a self-venting drain valve.

The 360° rotating cover allows quick installation in a convenient location. Options include an integral thermostat and 12V or 120V electric preheater.



The high grade aluminum components and powder coat paints mean that corrosion is never a worry.

A durable single bolt mounting bracket doubles resistance to vibration fatigue.

Aquabloc media sheds water and keeps engines waterproof, rustproof and dirtproof.

300-watt heaters start you in the cold – thermostats are standard to meet the requirements of today's electronic engines.

Polymer bowl withstands impact and temperature extremes.

Self-venting drain. A single twist makes draining clean, fast and easy.

With an Aquabloc II replacement element, you get a complete kit with all the seals you need.

Aquabloc II media is a blend of high grade cellulose compounded with resins and a special chemical treatment.

Aquabloc II elements filter harmful tiny particles of dirt and algae from fuel. Aquabloc II elements are rustproof – with polymer end caps that won't ever corrode.

The First Name In Fuel Filtration Is Also The Most Improved

Every engine runs better with a system that cleans fuel, removes water, heats fuel and senses when it's time for service. The system is the Racor Turbine Series and it's the most complete, most efficient, most reliable high-capacity engine protection you can install. A system that protects your investment in engines and fuel.

For marine rated filters see brochure #7501.

End caps are color-coded for easy identification and application – red for 30 micron primary filtration, blue for 10 micron primary or secondary, and brown for 2 micron secondary/final filtration.

Use original Racor filter elements to ensure premium performance.

An integral bail handle makes changeouts easy.

Our toll-free number is shown on the end cap. It puts you in touch with Racor's technical service staff who can answer any availability, application, or service question.



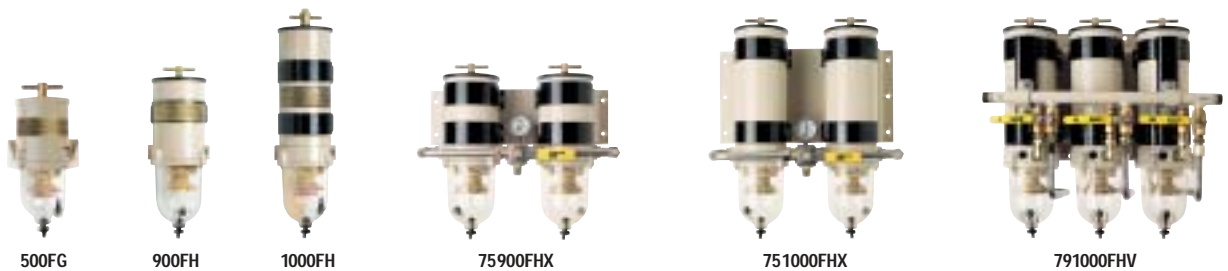

500FG

900FH

1000FH

75900FHX

751000FHX

791000FHV

| Model | 500FG | 900FH | 1000FH | 75500FGX | 75900FHX | 731000FH | 751000FHX | 771000FH | 791000FHV |
|---------------------------|-----------------------------|----------------------------|----------------------------|----------------------|--------------------------|---------------------|-----------------------------|---------------------|------------------------------|
| Maximum Flow Rate | 60 gph 227 lph | 90 gph 341 lph | 180 gph 681 lph | 120 gph 454 lph | 180 gph 681 lph | 360 gph 1363 lph | 180/360 gph 681/1363 lph | 540 gph 2044 lph | 360/540 gph 1363/2044 lph |
| Height | 11.5" / 292 mm | 17" / 432 mm | 22" / 559 mm | 11.5" / 292 mm | 17" / 432 mm | 22" / 559 mm | 22" / 559 mm | 22" / 559 mm | 22" / 559 mm |
| Width | 5.8" / 147 mm | 6" / 152 mm | 6" / 152 mm | 14.5" / 368 mm | 18.75" / 476 mm | 16.5" / 419 mm | 18.75" / 476 mm | 21.5" / 546 mm | 21.5" / 546 mm |
| Depth | 4.8" / 122 mm | 7" / 178 mm | 7" / 178 mm | 9.5" / 241 mm | 11" / 279 mm | 12" / 305 mm | 11" / 279 mm | 12" / 305 mm | 12" / 305 mm |
| Weight | 4 lbs / 1.7 kgs | 6 lbs / 2.7 kgs | 10 lbs / 4.5 kgs | 17 lbs / 7.7 kgs | 23 lbs / 10.4 kgs | 26 lbs / 11.8 kgs | 30 lbs / 13.6 kgs | 39 lbs / 17.7 kgs | 52 lbs / 23.6 kgs |
| Port Size Std. (Option) | 3/4" -16 UNF 16 mm x 1.5 | 7/8"-14 UNF 22 mm x 1.5 | 7/8"-14 UNF 22 mm x 1.5 | 3/4" -16 UNF | 7/8"-14 UNF ¹ | 3/4" NPT | 7/8"-14 UNF ¹ | 1"-11 1/2 NPT | 3/4" NPT |
| Clean Pressure Drop | 0.25 psi 1.72 kPa | 0.34 psi 2.4 kPa | 0.49 psi 3.4 kPa | 0.70 psi 4.83 kPa | 1.7 psi 11.7 kPa | 1.7 psi 11.7 kPa | 3.7 psi 25.5 kPa | 1.7 psi 11.7 kPa | 2.5 psi 17.2 kPa |
| Maximum Operating Pres. | 15 psi 103 kPa | 15 psi 103 kPa | 15 psi 103 kPa | 15 psi 103 kPa | 15 psi 103 kPa | 15 psi 103 kPa | 15 psi 103 kPa | 15 psi 103 kPa | 15 psi 103 kPa |
| Element # | 2010 | 2040 | 2020 | 2010 | 2040 | 2020 | 2020 | 2020 | 2020 |
| Element Removal Clearance | 4" / 102 mm | 5" / 127 mm | 10" / 254 mm | 4" / 102 mm | 5" / 127 mm | 10" / 254 mm | 10" / 254 mm | 10" / 254 mm | 10" / 254 mm |

Notes: (1) Male "JIC" 37" fittings.
 (2) Flow rates shown for one/both filters on-line.
 (3) Flow rates shown for two/all filters on-line.
 For accurate fuel flow rates consult your engine manual, engine manufacturer's agent or Racor distributor.

Manifold Units:
 • 75500, 75900 and 751000 double manifolds with shutoff valve.
 • 731000 double manifold without shutoff valves.
 • 791000 triple manifold with shutoff valves.
 • 771000 triple manifold without shutoff valves.



FBO Filter Assembly

Racor's new FBO-10 and FBO-14 filter assemblies are designed to meet the toughest hydrocarbon refueling conditions and provide for ease of filter change-outs. The FBO Assembly can flow 25gpm/95lpm or up to 75gpm/230lpm depending on the model, the elements installed and fuel being filtered.

The FBO assembly can be used on mobile refuelers or installed in refueling cabinets. The unit can also be used for diesel fuel dispensing pumps or as a primary fuel filter/water separator for large diesel engines.

The assembly features a locking ring collar, which attaches the filter housing to the aluminum die cast filter head with four bolts. The slotted locking ring collar allows maintenance personnel to hand-loosen the four collar bolts, rotate and lower the bowl assembly for element change-outs. With new element installed, simply raise the bowl and rotate into position on the locking ring and hand-tighten evenly.

The closure hardware consists of stainless steel nuts, bolts and washers with metal hand knobs for ease of maintenance – one person can easily change the filter element. No wrenches or other special tools are required.

Applications

- Jet fuel, aviation gas, diesel fuel, gasoline, kerosene, JP4, JP5 and JP8

Installations

- Aviation fuel trucks
- Aviation fueling cabinets
- Diesel fuel dispensing system
- Marine fuel docks
- Fuel systems on large diesel engines



Standard Design Features

- Die cast aluminum head
- Steel filter bowl assembly
- Powder coated components
- Locking ring collar, no clamps
- 1 1/2" NPT Inlet and Outlet
- 150 psi @ 240° F max design pressure
- Manual drain valve
- Manual vent valve
- Sight plug for water detection

Performance Specifications

| FBO-10 | Maximum Flow Rates | | | | Clean Dry | Change |
|------------|--------------------|--------|----------|----------|-----------|---------|
| | Flow Range | Diesel | Jet Fuel | Gasoline | Delta P | Delta P |
| Prefilter | 5-40 gpm | 20 | 40 | 50 | ** | 20 PSID |
| Filter Sep | 5-35 gpm | 18 | 35 | 45 | ** | 15 PSID |
| Absorber | 5-25 gpm | 18 | 35 | 45 | ** | 30 PSID |
| FBO-14 | Flow Range | Diesel | Jet Fuel | Gasoline | Delta P | Delta P |
| Prefilter | 10-60 gpm | 30 | 60 | 75 | ** | 20 PSID |
| Filter Sep | 10-50gpm | 25 | 50 | 65 | ** | 15 PSID |

** varies with fluid and flow rate

Spin-On Protection At The Pump



Racor's Fuel Dispensing Filters are essential for stationary and overhead tanks and mobile service vehicles, so you can start protecting your investment at the source. With their easy-to-install heads, they remove virtually 100% of the contaminants from diesel fuel.

Racor elements feature a super absorbent, chemically treated media

that absorbs 25 times its weight in water, "locking it in" as a barrier against free and emulsified water. There is no bypass valve, which ensures that fuel is completely protected. As the media swells, it significantly reduces the fuel flow rate, signaling a need to replace the element.

Racor offers filter protection down to 25 microns. Flow rates range from 15 to 100 gpm. Element service is clean and easy – there's no cartridge to replace – just spin-on a new Racor filter element.

Fuel dispensing filters can be used with diesel fuel or gasoline.



Filter Heads

| Part No. | HH07500 | FDH12500 | FDW125DD |
|----------------|-----------------|-----------------|---------------------|
| Port Size | 3/4" NPT | 1 1/4" NPT | 1 1/2" NPT |
| Element | FDW 3525 / 3825 | FDW 51125 | FDW 51125(2) |
| Element Thread | 1" – 12 UNF | 1 1/2" – 16 UNF | 1 1/2" – 16 UNF |
| Flow Rate | 15 gpm | 50 gpm | 100 gpm (Dual unit) |

Water Removing Filters

| Part No. | FDW 3525 | FDW 3825 | FDW 51125 |
|-----------------------|--|-------------------------------------|---|
| Nominal Micron Rating | 25 | 25 | 25 |
| Element Size | 3.7 D x 5.5 L | 3.7 D x 8.0 L | 5.0 D x 11.0 L |
| Element Thread | 1" – 12 UNF | 1" – 12 UNF | 1 1/2" – 16 UNF |
| Application | Truck fueling tanks; service station pumps | Truck or yard fueling tank; marinas | Truck terminal or truck stop pumps; marinas |

Maximum operating pressure of Fuel Dispensing Filter Heads and Water Removing Filters is 175 PSI (1207kPa).

Fuel Filter Funnels

The Racor Fuel Filter Funnel (RFF) family is a new heavy-duty, fast-flow, filter-in-a-funnel that separates damaging free water and contaminants from gasoline, diesel, heating oil, and kerosene.



The new RFF family of products is capable of removing free water and solids down to .005" and allows you to visually inspect the integrity of your fuel supply as you refuel.

The RFF family is manufactured using industrial grade black electro-conductive polypropylene. Carbon powder is injected into the plastic so that the RFF will conduct static electricity. The grounding capability of the RFF is an important safety feature. Always use proper fuel handling procedures and follow local, state, and federal regulations.

Hydrocarbon Filter Vessels & Elements with flow rates to 1000 gpm+.

Brochure number 7537



BVFS Series

Today's alternative fuels – compressed natural gas, liquid natural gas and liquid propane gas – have the same problems that plague diesel and gasoline... contamination that collects during handling, water that condenses in tanks and compressors that leak oil into the fuel stream.



The precision components necessary for the efficient operation of an alternative fuel system demand superior filtration.

The solution – the industry's first and most complete line of alternative fuel filter/coalescers and prefilter/strainers. From pipeline to engine – Racor fuel filter/coalescer products provide the ultra-fine filtration required by alternative fuels.

Protecting the fuel injectors and components of an alternative fuel system is vital to efficient vehicle operation. Racor offers the most complete line of fuel filter/coalescers and prefilter/strainers for on-vehicle applications. These filters ensure removal of damaging aerosol contamination as small as 0.3 to 0.6 micron and exceed 95% efficiency, depending on the grade of element specified. Units are available in a range of pressure ratings and are constructed of aluminum, stainless steel or painted steel.

The fuel filter/coalescer elements are produced by a patented process of arranging microglass fibers into a tubular form. During operation, fuel is forced through the coalescing media from the inside of the cartridge through the tubular wall to the outside, where the large droplets fall to the bottom of the housing. Oily water emulsion accumulates until drained while the dirt particles remain trapped on the surface of the fibers.

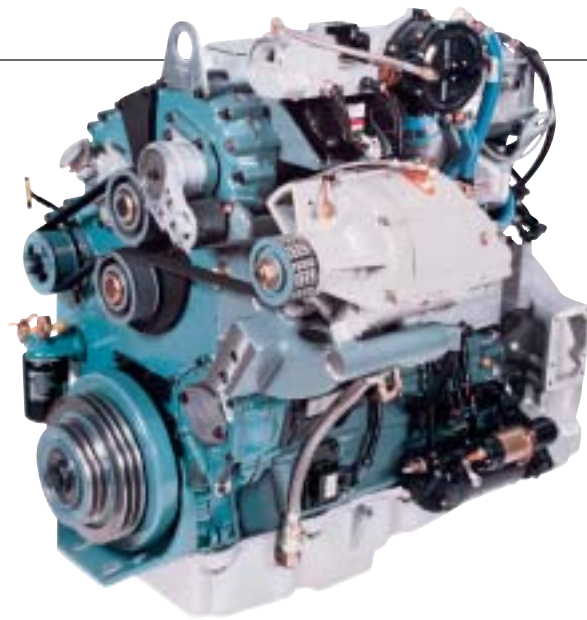

Prefilter/Strainers

Engineered and precisely manufactured to provide superior performance at operating pressures up to 500 psi, the compact, in-line prefilter/strainers are an essential first step in a complete filtration system.



Low Pressure Fuel Filter/Coalescers

Low pressure coalescers are ideal for operating environments up to 500 psi. All aerosol contaminants in the 0.3 to 0.6 micron range are filtered to an efficiency level that exceeds 95%.

High Pressure Fuel Filter/Coalescers

These patented coalescing filters are constructed to withstand operating pressures to 3600 psi. These coalescing filters remove over 95% of aerosols in the 0.3 to 0.6 micron range.



Engineered Modules/System

The combination of high pressure filters, regulators, fittings and brackets into one module allows manufacturers to specify one part number.

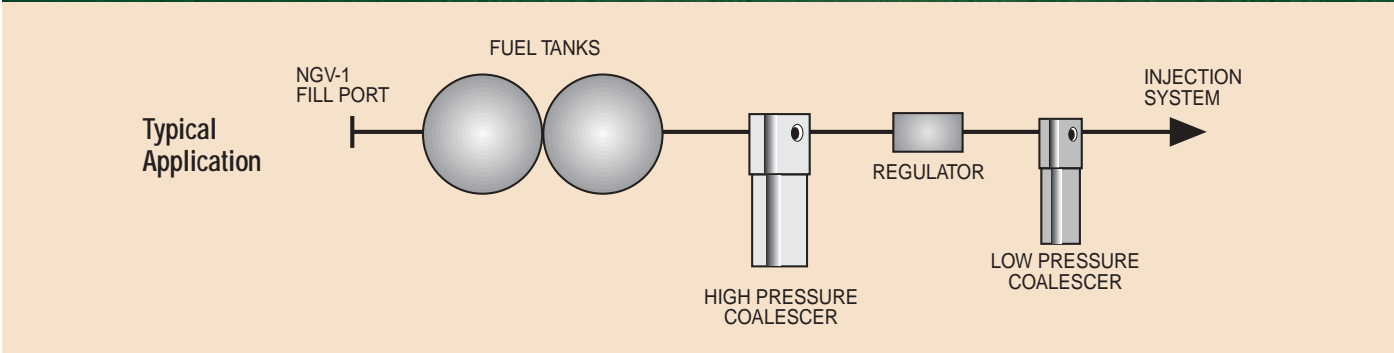

| | LOW | | | MEDIUM | HIGH | | |
|-------------------------|---------------------------|-------------------|-------------------|------------------------|----------------------|-------------------|-------------------|
| MODEL | FFC-119 | FFC-110 | FFC-110L | FFC-112 FFC-112-SAE | FFC-113 | FFC-114 | FFC-116 |
| Type | Prefilter/ Strainer | Coalescer | Coalescer | Coalescer | Coalescer | Coalescer | Coalescer |
| Port | 5/8" Outlet 1/4" Inlet | 1/4" NPT | 1/2" NPT | 1/4" NPT | 1/2" NPT 9/16 SAE | 1/2" NPT | 1/4" NPT |
| PSI (Max.) | 500 PSI | 500 PSI | 500 PSI | 3600 PSI | 3600 PSI | 3600 PSI | 3600 PSI |
| Rated Flow ⁵ | 25 | 25 | 50 | 15 | 50 | 50 | 8.4 |
| Length (in / mm) | 4.87" / 123.69 mm | 7.16" / 181.86 mm | 10.4" / 264.16 mm | 4.75" / 120.65 mm | 8.03" / 203.96 mm | 6.98" / 177.29 mm | 3.85" / 97.79 mm |
| Diameter (in / mm) | 2.63" / 66.80 mm | 3.13" / 79.50 mm | 3.13" / 79.50 mm | 2.25" / 57.15 mm | 2.97" / 75.43 mm | 2.97" / 75.43 mm | 1.75" / 44.45 mm |
| CNG | | • | • | • | • | • | • |
| LNG | | | • ² | | • ³ | • ³ | |
| LPG | • | • | • | | | | |
| Weight lbs. / kg | .5 lbs / .23 kg | 1.5 lbs / .68 kg | 1.8 lbs / .82 kg | 1.5 lbs / 0.68 kg | 5.5 lbs / 2.49 kg | 5.25 lbs / 2.3 kg | 1.75 lbs / .79 kg |
| Element Number | N/A | CLS110-10 | CLS110-10L | CLS112-10 | CLS113-6 | CLS113-6 | CLS116-10 |
| Sump Capacity Oz. | N/A | 5.0 | 7.0 | 0.5 | 5.0 | 3.0 | 0.25 |
| Material | Painted Steel | Painted Steel | Painted Steel | Stainless Steel | Anodized Aluminum | Stainless Steel | Stainless Steel |

Notes: (1) Use in conjunction with coalescer.
 (2) Low flow rate LNG applications.
 (3) Medium flow rate LNG applications. Bypass included.
 (4) High flow rate LNG applications. Bypass included.
 (5) SCFM at 100 PSIG.

When there's a need to add an extra fuel heating measure of protection, or where filtration systems are already in place, Racor offers a number of efficient heaters. Compact coolant and electric heaters install in minutes, yet deliver years of trouble-free service. There is even an in-line heater which actually turns a fuel line into a heated path from tank to filter.



Coolant Heater

Plumbed into the fuel upstream from filters, the coolant heater is another compact way to run through the cold. An optional internal thermostatically-controlled valve allows fuel to bypass the heater once it has reached operating temperature. Depending on fuel flow rate, you can get as much as 89°F heat rise.

Like its electric partner, there are no moving parts, nothing to rust or corrode.



Coolant Heaters

The Racor ECH™ tank-type coolant heaters operate using the thermo-siphon circulation principle. Heated coolant is returned to the engine as colder coolant is drawn into the heater.

By utilizing standard alternating current (AC) from the customer-supplied source, they heat and maintain the engine coolant at a pre-determined temperature range. This warm coolant helps keep the engine ready for instant operation. Racor ECH tank-type coolant heaters are mounted off the engine for long life and increased wattage output.

Note: Not for use as fuel heaters.



- Racor ECH tank-type coolant heaters can meet all diesel generator heating requirements regardless of engine size.
- Weather-tight construction.
- All ECH components carry the CSA (Canadian Standards Association) approval and CE (European Union) mark.
- Thermostatic controls ensure proper and efficient operation of the ECH tank-type coolant heaters.

In-Line Diesel Fuel Heater

| Part No. | 320HTR4 | 320HTR4T |
|--------------------------------|--------------|--------------|
| Heater(s) | Coolant | Coolant |
| Internal Thermostat | No | Yes |
| Horsepower Rating ¹ | Up to 300 hp | Up to 300 hp |



The 500 watt electric in-line heater has a cab control switch.

Electric Heaters

The Racor Nomad Diesel Fuel Heater is available in 300 and 500 watts and is one of the most compact, most efficient ways to heat fuel on the road today. Installation usually takes about an hour. An optional frame rail mounting bracket eliminates drilling and welding.

In-Line Diesel Fuel Heater

| Part No. | 14257 | 14278 | 14279 |
|--------------------------------------|----------------|--------------|--------------|
| Heater(s) | Electric | Electric | Electric |
| Watts | 500 W | 300 W | 300W |
| Voltage | 12V | 12V | 24V |
| Internal Thermostat | In-Cab Control | Yes | Yes |
| Horsepower Rating ¹ | 200-300 hp | Up to 200 hp | Up to 200 hp |
| Nominal Current Draw | 35.7 | 21.4 | 10.5 |
| Min. Alt. Rating ² | 75 | 65 | 65 |
| 5 Min. Preheat Amp Hrs. ³ | 3.0 | 1.8 | 3.8 |

The Heavy-Duty In-Fuel-Line Diesel Heater replaces the fuel line between tank and primary filter. It prevents power loss and assists starting down to -40°F.

Racor electric heaters come as factory pre-wired kits with all hardware, ready for quick installation.



In-Fuel-Line Diesel Fuel Heater

| Part No. | 30012V | 30024V | 50012V | 50024V |
|--------------------------------------|----------------|----------------|----------------|----------------|
| Heater(s) | Electric | Electric | Electric | Electric |
| Watts | 300 W | 300 W | 500 W | 500 W |
| Voltage | 12V | 24V | 12V | 24V |
| Internal Thermostat | In-Cab Control | In-Cab Control | In-Cab Control | In-Cab Control |
| Horsepower Rating ¹ | 100-200 hp | 100-200 hp | Over 200 hp | Over 200 hp |
| Nominal Current Draw | 21.4 | 10.7 | 35.7 | 17.9 |
| Min. Alt. Rating ² | 65 | 40 | 75 | 45 |
| 5 Min. Preheat Amp Hrs. ³ | 1.8 | 0.9 | 3.0 | 1.5 |
| Length | 8' (2.44 M) | 8' (2.44 M) | 12' (3.66 M) | 12' (3.66 M) |

¹ Use specifications for horsepower ratings as general guideline only.

² For on-highway trucks, this assumes concurrent use of high-beam headlamps, tractor lights, heater blower and minimum trailer lighting. Use of many electrical accessories will increase the necessary alternator rating.

³ Amp hour draw for 5 minutes preheat. For on-highway trucks this assumes concurrent use of high-beam headlamps, tractor lights, heater blower and minimum trailer lighting. Use of many electrical accessories will increase the necessary alternator rating. Most 12V heavy-duty batteries are rated at approximately 80 amp hours.



Battery Warming Pads

Racor battery warming pads fit under the engine's battery to help it maintain higher cold cranking capacity.

Racor Battery Heaters

| Watts | Voltage | Part Number |
|-------|---------|-------------|
| 50 | 120 | 86005-X1-00 |
| 50 | 240 | 86005-X2-00 |
| 75 | 120 | 86005-X3-00 |
| 75 | 240 | 86005-X4-00 |
| 80 | 120 | 86005-X5-00 |
| 80 | 240 | 86005-X6-00 |
| 100 | 120 | 86005-X7-00 |
| 100 | 240 | 86005-X8-00 |
| 160 | 120 | 86005-X9-00 |

Hot Pads

Racor peel-and-stick hot pads can be applied to components such as oil pans, hydraulic reservoirs, and diesel fuel tanks to offer localized spot heating.

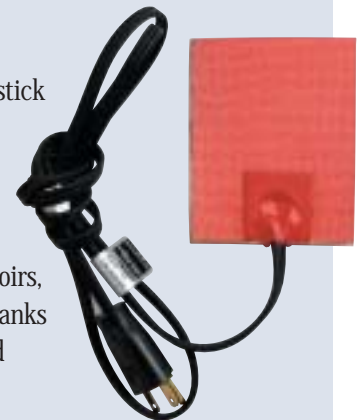

Racor Hot Pads

| Watts | Voltage | Part Number |
|-------|---------|-------------|
| 100 | 120 | 86016-Y1-00 |
| 100 | 240 | 86016-Y2-00 |
| 150 | 120 | 86016-Y3-00 |
| 150 | 240 | 86016-Y4-00 |
| 250 | 120 | 86016-Y5-00 |
| 250 | 240 | 86016-Y6-00 |
| 400 | 120 | 86016-Y7-00 |
| 400 | 240 | 86016-Y8-00 |

We've Bottled Racor Protection

Racor Additives are performance-enhancing products for all climates and seasons. There are several convenient sizes, including 1 and 2.5 gallon bottles and a 16 oz. bottle that makes measuring quick and easy. The high concentration of active ingredients in Racor additives allows for higher treatment rates. All Racor Fuel Additives are alcohol-free.

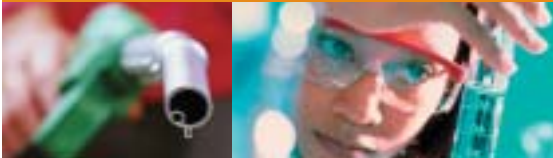

alcohol-free
additives



A convenient spout extension is available for quick, clean service. The spout fits 16 oz. bottles only. Order RK 21644.

Diesel Biocide

Racor Diesel Biocide is a multifunctional petroleum distillate fuel additive. It is used to help maintain color stability and clarity; control bacteria, fungi, organic reaction and sludge formation; inhibit corrosion; and disperse existent sludge.

EPA Est. No. 072342-CA-001. EPA Reg. No. 1448-172-47099.

Available in 55 gallon drum
Part # ADT 2555



- Concentrated, extended time formula.
- EPA approved as both a biocide and aftermarket fuel additive.
- Provides superior mixing with fuel at all temperatures.
- Fuel and water soluble.
- Does not cause foaming.

Part # ADT 2201

Diesel Conditioner Plus+

Racor Diesel Conditioner Plus+ is a multi-functional fuel additive for all-season use. Its formulation contains a cetane improver which enhances power delivery, starting and helps engines run smoother and quieter. Its lubricity additives reduce friction, as well as corrosion and rust formation.

Available in 55 gallon drum
Part # ADT 1555



- Cetane improver for added engine performance.
- Dissolves gum and varnishes to keep fuel system clean.
- Passes the BOCLE test for lubricity.
- Reduces rust and corrosion in the fuel system.
- Stabilizes fuel quality during prolonged storage.

Part # ADT 1201

Diesel Performance Plus+

Racor Diesel Performance Plus+ has the same engine protection qualities of Racor Diesel Conditioner Plus+ and it has five times the Cetane improver to deliver optimal engine performance. The added performance comes with improved lubricity and is alcohol-free for better fuel system component protection.



- Five times the Cetane improver of Diesel Conditioner Plus+.
- Dissolves gum and varnishes to keep fuel system clean.
- Lubricity improver passes HFRR Lubricity Test for diesel fuel per ASTM D6079-99.
- Stabilizes fuel and prevents corrosion per ASTM D665A.

Part # ADT 3116

Diesel Winter Plus+

Racor Diesel Winter Plus+ is added to middle petroleum distillates such as No. 2 heating oil or diesel fuel to improve their low temperature operability as measured by pour pint and cold filter plugging point. Racor Diesel Winter Plus+ prevents the plugging of lines, filter screens and valves and allows the fuel to flow freely down to -32° F (-36° C). Diesel Winter Plus+ contains a de-icer, which can help reduce line freezing.



- Improves fuel flow and facilitates cold weather starting.
- Improves efficiency of fuel filter/water separators through demulsification.
- Contains a Cetane improver and de-icer.
- Smoother, quieter engine operation.
- Prevents corrosion.
- Stabilizes fuel quality during prolonged storage.

Part # ADT 4116

Gasoline Conditioner Plus+

Racor Gasoline Conditioner Plus+ is a diluted multifunctional gasoline additive which cleans as it protects. It is designed for secondary treatment applications and can be used with all types of internal combustion systems and gasoline blends. It provides better combustion, better fuel economy and lower exhaust emissions.



- Protects intake system against corrosion.
- Prevents accumulation of deposits.
- Improves efficiency of fuel filter/water separators through demulsification.
- Will not harm lube oil or catalytic converters.
- Stabilizes quality of stored gasoline.

Part # ADT 5116

Coolant Treatment

Racor Coolant Treatment is a combustion corrosion inhibitor and iron oxide/scale dispersant. Its unique formulation protects all types of metals, including aluminum, in diesel and gasoline engine cooling systems.



- Stabilizes engine coolants.
- Neutralizes hard water salts, helps prevent overheating, disperses silica deposits and contains an anti-foam agent.
- Maintains heat transfer in closed cooling systems.

Part # ADT 8116

POWERSHOT+ Diesel

Racor POWERSHOT+™ Diesel Fuel Conditioner is recommended for use in all engine applications using #1 or #2 diesel fuels. One 11 ounce bottle treats up to 30 gallons of diesel fuel, and will dramatically improve fuel economy, enhance fuel stability in storage and provide excellent protection from corrosion.



- Increases Cetane number resulting in reduced engine knock, improved low temperature starting, smoother idling, shortened warm-up time, and reduced emission.
- Removes deposits from fuel system, injectors, intake and combustion chamber.
- Provides exceptional fuel lubricity for reducing fuel pump & injector wear.

Part # ADT 1111

POWERSHOT+ Gas

Racor POWERSHOT+™ Gasoline Fuel Conditioner is a convenient gasoline additive that cleans while it protects. It can be used in all types of internal combustion systems and gasoline blends. By cleaning the engine's fuel injectors or carburetor, Racor POWERSHOT+™ Gasoline Fuel Conditioner provides better combustion, better fuel economy and lower exhaust emissions.



- Safely removes and prevents the accumulation of deposits.
- Protects intake system against corrosion.
- Lubricates and conditions fuel injection systems.
- Improves efficiency of fuel filter/water separators.
- Will not harm catalytic converters.
- Enhances fuel stability in storage.

Part # ADT 5111

Lube Oil Treatment

Racor Lube Oil Treatment is a fluorocarbon oil additive which contains an advanced, highly effective polymer lubricant. It provides a superior thin coating to protect precision engine parts, and does not contain PTFE or Teflon®, which have been known to fall from suspension and clog precision engine components. It may be used with diesel and gasoline engines and is compatible with all motor oils including synthetics.



- Reduces noise and heat in diesel and gasoline engines.
- Anti-corrosion formula.
- Increases mileage, engine life and performance.
- Reduces friction on cold start-up.
- Prevents premature wear on piston rings and cylinder walls, reducing harmful exhaust emissions.

Part # ADT 7116

Full Synthetic 15-40 Motor Oil

This premium fully synthetic engine oil is crafted with the highest quality synthetic base stocks and additive systems which provide superior film strength and oxidation resistance as well as exceptional soot and deposit control. High TBN, coupled with superior performance, premium detergent additives, premium dispersant additives and a high viscosity index afford engines maximum protection even in the harshest of operating conditions.



- Prevents rust, corrosion – and reduces engine wear.
- Provides extended drain intervals.
- Improves fuel economy and provides low temperature protection.

Part # ADT 9332

Vacuum / Compound Gauge Kits

Vacuum and Compound (vacuum/pressure) gauges and related hardware are available to monitor element condition. As the filter element slowly becomes clogged with contaminants the restriction (resistance to flow) increases. The fuel pump still tries to draw fuel (suction) but because of this restriction less fuel is delivered to the engine and instead more air is pulled from it (fuel de-gassing). These results can cause the engine to lose power and eventually stall.

By installing a vacuum gauge in your fuel system (at the outlet side of the Racor filter) visual monitoring of element condition is possible at a glance. Note the position of the dial, or apply the 'red line' decal provided with most kits. This will assist in easy monitoring as filter efficiency begins to decrease when a filter change is necessary.



1606B Gauge

Note: Intervals of element changeout may vary depending on fuel cleanliness. Always keep a spare Racor element on hand.

Compound gauges are recommended for applications where pressure is occasionally present. These conditions are typically a result of 'head' pressure which is present in overhead fuel tank installations. Whatever the reason, compound gauges should be used because damage may result if a straight vacuum-only gauge is used.

| Kit Part No. | Description | Application Suction (vacuum) or Pressure |
|--------------|--|---|
| RK11233 | Vacuum Gauge, all liquid filled out, 2" dial, 0–30 in.Hg. with 1/4" NPT back bracket mount. | Vacuum (Suction) or Pressure |
| 1606B | Vacuum Gauge Kit. Gauge (RK11233), one 7232–4 & 7234–4 fitting. Instrument panel installation. #4 hose not included. | Vacuum (Suction) or Pressure |
| 7232–4 | Adapter fitting, 1/8"NPTM X#4 (1/4") hose. Use with 0102–4–2 fitting, if needed. | |
| 7234–4 | Adapter fitting, 1/4" swivel X #4 (1/4") hose. Use with all gauges, if needed. | |
| 0102–4–2 | Adapter fitting, straight 1/4" NPTM x 1/8" NPTF. For use with 7232–4 / 7234–4 fittings, if needed. | |
| RK11–1676 | Vacuum Gauge. all liquid filled out, 2" dial, 0–30 in.Hg. With 1/4" NPT bottom boss mount. | Vacuum (Suction) or Pressure |
| RK11–1669 | 'T-Handle' Vacuum Gauge Kit. Includes Gauge (11–1676) and lid fitting (11–1668). | Vacuum (Suction) or Pressure |
| RK18–1104 | Compound Gauge, liquid filled, 2" dial, 0–30 in.Hg. / 0–30 psi. 1/4" NPT back bracket mount. | Vacuum (Suction) or Pressure |
| RK18–1551 | Compound Gauge, liquid filled, 2 1/2" dial, 0–30 in.Hg / 0–30 psi. 1/4" NPT back boss mount. | Vacuum (Suction) or Pressure |
| RK19476 | Compound Gauge, 2" dial, 0–25 in.Hg. / 0–15 psi. 1/4" NPT bottom boss mount. | Vacuum (Suction) or Pressure |

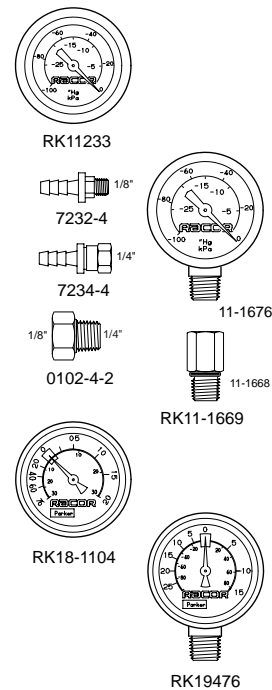

Vacuum Gauge or Switch Adapter Fittings

| Fitting Part No. | Old Part No. | Use with: | Thread 1 | Fitting end 2 | Qty. |
|--|--------------|-------------|----------|---------------|------|
| 913-O6-D6 | 9010HF6-6DTB | 500 Series | 9/16"-18 | 3/8" hose | 10 |
| Features 1/8" NPTF to attach vacuum gauge hose fitting. | | | | | |
| 911-O8-D8 | New | 500 / 4120R | 3/4"-16 | 3/4"-16 SAE | 10 |
| 911-O10-D10 | New | 900 / 1000 | 7/8"-14 | 7/8"-14 SAE | 10 |
| 9040-10-DT | No change | 900 / 1000 | 7/8"-14 | 1/2"-14 NPTF | 10 |
| Both above feature 1/4" NPTF to attach vacuum gauge or hose fitting. | | | | | |

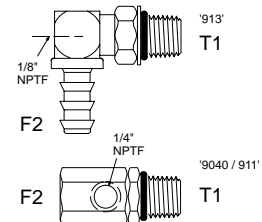

Water Detection Modules & Kits





Racor Water Detection Kits are available in a wide selection for various installation requirements. Under dash, in-dash and remote mount, these solid-state units may be used with any Racor fuel filter/water separator and water probe. They are manufactured using the highest quality materials and are all 100% electrically tested.

An electronic detection module analyzes electrical resistance at the water probe and determines if water is present.

If so, the detection module operates to indicate water, based on its features listed below. All units reset automatically after water is removed (unless specified).

Caution: The water probe and detection modules work with 12 or 24 volts, direct current only and should never be wired to other brand modules or household 110 or 220 volts, alternating current.

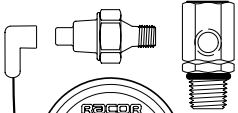
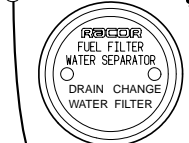
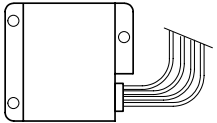
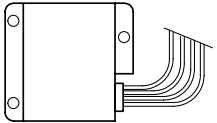
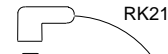
Use the guide below to find the correct detection module for your application.

| Kit Part No. | | Use with the following voltage: | |
|--------------|--|---|--|
| RK12870 | Under dash Water Detection Module illuminates and sounds when water is detected. Water must be drained to reset light and stop horn. Plastic enclosure measures: 1.38" square x 1.25 deep. | 12V DC |  RK12870 / RK12871 |
| RK12871 | Under dash Water Detection Module, same as above. | 24V DC | |
| RK20725 | Under dash Mount Water Detection Module. Light only. Green 'ON' lamp illuminates with power and red 'DRAIN' lamp illuminates when water is detected. Initial power – up self diagnosis feature and circuit protection included. Plastic enclosure measures: 2.75" x 1" x 1.5" | 12V DC |  RK20725 / RK20725-24 |
| RK20725-24 | Under dash Water Detection Module, same as above. | 24V DC | |
| RK20726 | 2" Gauge Type Water Detection Module. Light and audio. Red 'DRAIN' lamp illuminates continuously and horn sounds momentarily when water is detected. Initial power-up self diagnosis feature and circuit protection included. Plastic case, satin black dial with white lettering. | 12 or 24V DC |  RK20726 |
| RK30056 | 2" Gauge Type Water Detection Module and Water Probe Kit. (Module RK20726 and Probe RK21069, with 1/2"-20 threads). | 12 or 24V DC Bowl must have water probe port |  |
| RK11-1570 | 2" Gauge Type Water Detector & Filter Restriction Module. Includes pre-set vacuum switch (7in.Hg.), connector and outlet adapter fitting. Red 'DRAIN' or 'CHANGE FILTER' lamp illuminate continuously and horn sounds momentarily when water is detected. Probe not included. Steel case, black dial with white lettering. | 12 or 24V DC For units with 7/8" SAE ports |  RK11-1570 |
| RK14329 | Remote Detection Unit. Sends 12V DC hot (+) signal when an input ground signal (from a water probe or a vacuum switch – not included) is received. Must be used with a relay to power a horn or indicator lamp (if draw is over 1 amp). Plastic enclosure measures: 3" x 2.5" x .75" | 12V DC | |
| RK14321 | Remote Detection Unit. Same as above but sends 24V DC hot (+) signal. | 24V DC |  |
| RK14332 | Under dash mount. Same as RK14329 but sends a ground (-) signal. Enclosure size is same as RK20725, above. | 12V DC |  RK14329 / RK14321 |
| RK20163 | Vacuum Switch Kit. 12 or 24V DC, non-adjustable, 'NORMALLY OPEN' contacts close at 7 in.Hg., 118" NPT threads. For use with all models. | |  RK21030 |
| RK21030 | Vacuum Switch Connector Kit (for use with above). Molded connector with single 18 AWG., 18" blue wire lead. | |  RK20163 |

Primary (Pre-) Fuel/Water Separator For Vacuum Applications And Final Fuel For Pressure Applications

Fuel is drawn out of the fuel reservoir by the lift pump into and out of the pre-fuel filter/water separator. The fuel is pre-filtered through a 10 to 30 micron rated filter which also removes harmful water, thereby protecting the lift pump and injection system. The lift pump pressurizes the pre-filtered fuel into the final filter. Fuel is then filtered by a 1 to 7 micron rated filter, ensuring purified fuel is delivered. The combination filtration system design provides superior protection for heavy-duty applications where high levels of contamination and high volumes of fuel require a high filter capacity. Fuel conditioning options (drain, water sensor, hand primer pump, heater, etc.) are usually installed in the primary assembly.

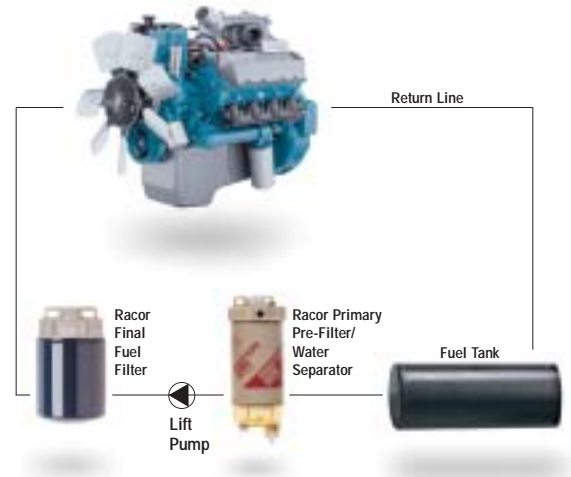

Secondary (Final) Fuel Filter/Water Separators For Vacuum Applications

This design integrates the primary fuel filter/water separator and final fuel filter into one system that is installed prior to the lift pump. The single assembly provides total filtration (1 to 7 microns) and water separation for the entire fuel system. This filtration system design provides excellent protection for applications where cost and service constraints are a challenge. Sufficient space for an adequate size combination unit must be available.

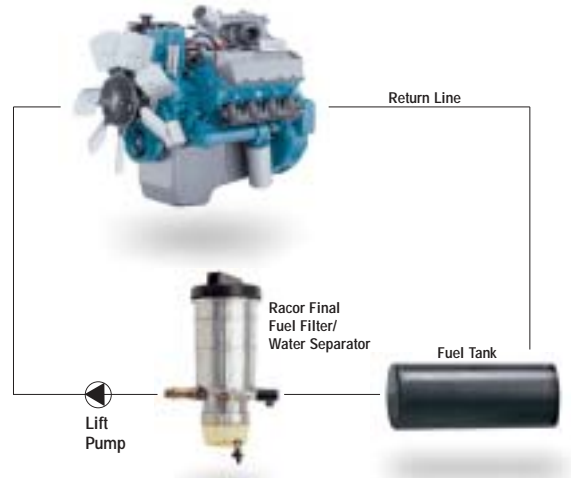

Secondary (Final) Fuel Filter/Water Separators For Pressure Applications

This design integrates the primary fuel filter/water separator and final fuel filter into one compact system that is installed after the lift pump. Generally, an in-fuel reservoir filter screen (100 to 200 micron) is utilized to complete the filtration system. The final fuel filter/water separator is installed after the lift pump and provides protection (1 to 7 microns) to the high pressure injection system. This filtration system design provides economical fuel injection system protection for small diesel engines, automotive and light-truck applications that already have generally good fuel quality and a relatively low volume of fuel usage.

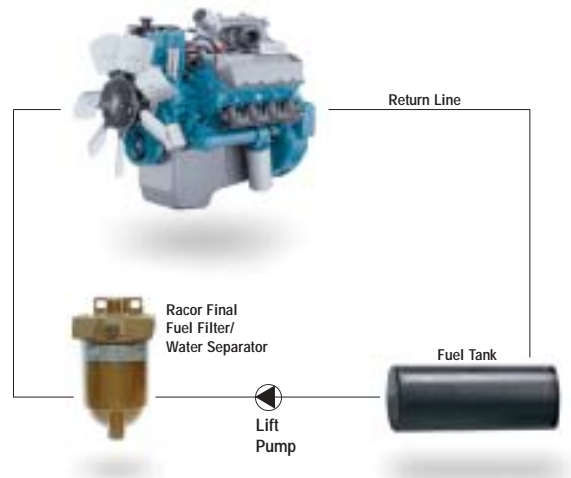

Typical Filter/Separator Options



Heavy-Duty Air Cleaners & Replacement Elements

Racor has expanded its air filtration family of products to include Heavy-Duty Air Cleaners and replacement air filter elements (formerly Farr Transportation Products Group). These high-capacity, efficient and flexible products expand the breadth of line that Racor customers have grown to expect.

Brochure number 7567



Heavy-Duty Combination Air Filters & Pre-Cleaners

Racor Combination Air Filters and Pre-Cleaners are designed to be connected to the air intake or to replace the existing standard air cleaner on diesel and gasoline engines. There is a wide range of centrifugal pre-cleaners and combination air filter/centrifugal pre-cleaners for agricultural machinery; earth-moving equipment; stationary engines; generator sets; trucks, buses and recreational vehicles; material handling equipment; snow removal equipment and street sweepers.

Brochure numbers 7555, 7558, 7559, 7560, 7561 and 7562



Marine Air Filter/Silencers & Crankcase Ventilation Filtration Systems

Racor Marine Air Filter/Silencers and Crankcase Ventilation Filtration Systems help to keep marine engines and engine rooms contaminant and vapor free. The patented CCV™ contains Racor's high-performance Vaporbloc™ filter made with depth-loading, engineered fiber-coalescing media. The marine air filter/silencer contains a washable media and is designed to connect easily to the Racor CCV to complete the system.

Brochure numbers 7496 and 7501



Marine Air Replacement Filters

Racor now offers replacement filters for marine applications. These filters are direct replacements for the intake air filter portion of various brands of air filters/silencers.

Brochure number 7501



Cleanable Oil Filtration Systems

These revolutionary systems replace lube oil and other filters with a cleanable stainless steel wire cloth filter. The service alert signals that the reusable filter has reached capacity. A quick wash-up in a solvent and you're back in operation.



- For diesel or gasoline engines
- A reliable diagnostic tool
- More cost-effective than paper-type oil filters
- Filter disposal and related liabilities are eliminated



Full-Flow Remote-Mount LFS

Bypass Oil Filtration Systems

Removes dirt, varnish, ash, tar, soot and other contaminants along with condensed water which forms damaging acids if left in the oil.



Bypass Oil LFS

Brochure number 7460



Technical CD-Rom

Racor Parts, Service and Technical Information is available on CD-Rom.

Order part number 7480F-CD-Rom @ \$5.00 each. The information is also available online at www.parker.com/racor; click on Technical Information.



Filtration Technology

The second edition of Filtration Technology is now in print. Parker's 250-page illustrated textbook covers the broadest range of filtration information ever assembled under one cover. The text is designed for anyone interested in industrial filtration; including engineers, educators, managers, distributors, salespeople and students.

Copies of Filtration Technology 2nd Edition are \$36.25 each, plus \$4.50 for shipping and handling. To order, send a check payable to Parker Hannifin c/o Motion Control Training, MS W3MC01, 6035 Parker Blvd., Cleveland OH 44124-4141. To charge by phone using VISA or MasterCard call (216) 896-2495.



*Need assistance?
Call our customer
service hotline:*

800/344-3286

209/521-7860



WARNING: Failure or improper selection or improper use of the products and/or systems described herein or related items can cause death, personal injury and property damage. This document and other information from Parker Hannifin Corporation, its subsidiaries and authorized distributors provide product and/or system

options for further investigation by users having technical expertise. It is important that you analyze all aspects of your application and review the information concerning the product or system in the current product catalog. Due to the variety of operating conditions and applications for the products or systems, the user, through its own analysis and testing, is solely responsible for making the final selection of the products and systems and assuring that all performance, safety and warning requirements of the application are met. The products described herein, including with limitation, product features, specification, designs, availability and pricing, are subject to change by Parker Hannifin Corporation and its subsidiaries at any time without notice.

Aerospace Group

A leader in the development, design, manufacture and service of control systems and components for aerospace and related high technology markets, achieving profitable growth through premier customer service.



Automation Group

A leading supplier of pneumatic and electro-mechanical components and systems to automation customers worldwide.



Climate & Industrial Controls Group

Designs, manufactures and markets system-control and fluid-handling components and systems to refrigeration, air-conditioning and industrial customers worldwide.



Filtration Group

Designs, manufactures and markets quality filtration and clarification products, providing customers with the best value, quality, technical support and global availability.



Fluid Connectors Group

Designs, manufactures and markets rigid and flexible connectors and associated products used in pneumatic and fluid systems.



Hydraulics Group

Designs, produces and markets a full spectrum of hydraulic components and systems to builders and users of industrial and mobile machinery and equipment.



Instrumentation Group

A global leader in the design, manufacture and distribution of high-quality critical flow components for worldwide process instrumentation, ultra-high purity, medical and analytical applications.



Seal Group

Designs, manufactures and distributes industrial and commercial sealing devices and related products while providing superior quality and total customer satisfaction.



About Parker Hannifin Corporation

Parker Hannifin is a leading global motion-control company dedicated to delivering premier customer service. A Fortune 200 corporation, we are listed on the New York Stock Exchange with PH as our symbol. Our components and systems comprise over 1,000 product lines that control motion in a wide spectrum of essential uses in some 1,200 industrial and aerospace markets. Parker is the only manufacturer to offer its customers a choice of hydraulic, pneumatic, and electro-mechanical motion-control solutions.

Our Company has the largest distribution network in its field, with over 6,000 distributors serving more than 300,000 customers worldwide.

Parker's Charter

We will be a leading worldwide manufacturer of components and systems for the builders and users of durable goods. More specifically, we will design, market and manufacture products controlling motion, flow and pressure. We will achieve profitable growth through premier customer service.

Product Information

Parker Hannifin's North American customers seeking product information, the location of a nearby distributor or repair services will receive prompt attention by calling the Parker Product Information Center at our toll-free number: 1-800-C-PARKER (1-800-272-7537). In the United Kingdom, a similar service is available by calling 0500-103-203.

Filtration Group Technical Sales & Services Locations

Parker Worldwide Sales Offices

Contact Parker's worldwide service and distribution network by calling:

Filtration and Separation Division

100 Ames Pond Drive
Tewksbury, MA 01876-0962
Phone: (978) 858-0505
Fax: (978) 858-0198

260 Neck Road
Haverhill, MA 01835-0723
Phone: (978) 858-0505
Fax: (978) 374-8093

500 Gaspie Street
Oxford, MI 48371
Phone: (248) 628-6400
Fax: (248) 628-1850

611-M Hammonds Ferry Road
Linthicum, MD 21090
Phone: (410) 636-7200
Fax: (410) 636-7206

Hydraulic Filter Division

16810 Fulton County Road #2
Metamora, OH 43540
Phone: (419) 644-4311
Fax: (419) 644-6205

1273 N. Church Road
Moorestown, NJ 08057
Phone: (856) 866-9002
Fax: (856) 866-9112

Racor Division

3400 Finch Road
P.O. Box 3208
Modesto, CA 95353
Phone: (800) 344-3286
Phone: (209) 521-7860
Fax: (209) 529-3278

302 Parker Drive
Beaufort, SC 29902

805 North West Street, PO Box 6030
Holly Springs, MS 38635

Process Filtration Division

6640 Intech Blvd.
Indianapolis, IN 46278
Phone: (317) 275-8300
Fax: (317) 275-8410

State Road 66
Tell City, IN 47856
Phone: (812) 547-2371
Fax: (812) 547-2380

Filter Division Europe

Churwell Vale
Shaw Cross Business Park
Dewsbury, England WF12 7RD
Phone: (44) 1924 487000
Fax: (44) 1924 487060

Fin-31700
Urjala As., Finland
Phone: (358) 3 54 100
Fax: (358) 3 54 10100

Teollisuustie 2
89400 Hyrynsalmi
Finland
Phone: (358) 8 6532500
Fax: (358) 8 6532520

Oude Kerkstreet 4
P.O. Box 258
4870 AG Etten-Leur
The Netherlands
Phone: (31) 76 508 53 04
Fax: (31) 76 508 53 12

Filtration Group Headquarters

6035 Parkland Blvd.
Cleveland, OH 44124-4141
Phone: (216) 896-3000
Fax: (216) 896-4021
<http://www.parker.com/filtration>

Parker Hannifin Ind. e Com.
Ltda, Filter Division
05276-977 - Sao Paulo
- SP, Brazil
Phone: +55 (11) 3917 1407
Fax: +55 (11) 3917 7898

Parker Hannifin Korea Limited
902 Dae Heung Bldg.
648-23 Yeoksam-dong
Kangnam-ku, Seoul,
Korea 135-080
Phone: 82 2 561 0414
Fax: 82 2 556 8187

Argentina • +54 (3227) 44 4129

Australia • +61 (2) 634 7777

Austria • +43 (2622) 23501 5

Belgium • +32 (2) 762 1800

Brazil • +55 (11) 3917 1407

Canada • 1-800-272-7537

Central & South America/Caribbean • 1-305-470-8800

China • +86 (21) 6445 9339

Czech Republic • +42 613 41701

Denmark • +45 (43) 541133

Finland • +358 3 54 100

France • +33 02 54 74 03 04

Germany • +49 (3727) 90991

Hong Kong • +852 2428 8008

Hungary • +36 (1) 25 22 539

India • +91 (22) 577 1671

Italy • +39 (2) 451921

Japan • +81 (45) 861 3811

Korea • +82 (2) 561 0414

Mexico • 1-800-272-7537

Netherlands • +31 (541) 58500

New Zealand • +64 (9) 573 1523

Norway • +47 (64) 867760

Poland • +48 (22) 8634942

Singapore • +65 261 5233

South Africa • +27 (11) 3927280

Spain • +34 (1) 6757300

Sweden • +46 (8) 760 2960

Taiwan • +886 (2) 8787 3780

Thailand • +662 693330

United Arab Emirates • +971 (2) 788587

United Kingdom +44 1442 238100

United States of America • 1-800-272-7537

Venezuela +58 (2) 238 5422

anything  Possible.

Parker Hannifin Corporation

Racor Division
P.O. Box 3208
Modesto, CA 95353 USA
800/344-3286
209/521-7860
Fax 209/529-3278
<http://www.parker.com/racor>
e-mail: racor@parker.com

Brochure No. 7529 USA
09/04 20M