

Closed Crankcase Ventilation Filtration Systems Technical Information



Crankcase Filtration

Legislative requirements to reduce exhausted emissions began in the 1960's on passenger cars. On-highway diesel engines were required to reduce emissions as well, but unlike passenger vehicles, these large diesel engine powered trucks were not required to deal with crankcase emissions. In 2007, the US EPA has required engine manufacturers to include crankcase emissions for all on-highway diesel engines.

Crankcase emissions or "blow-by" as it is commonly referred to, are the gases and hydrocarbons that are pushed out of the crankcase during engine operation.

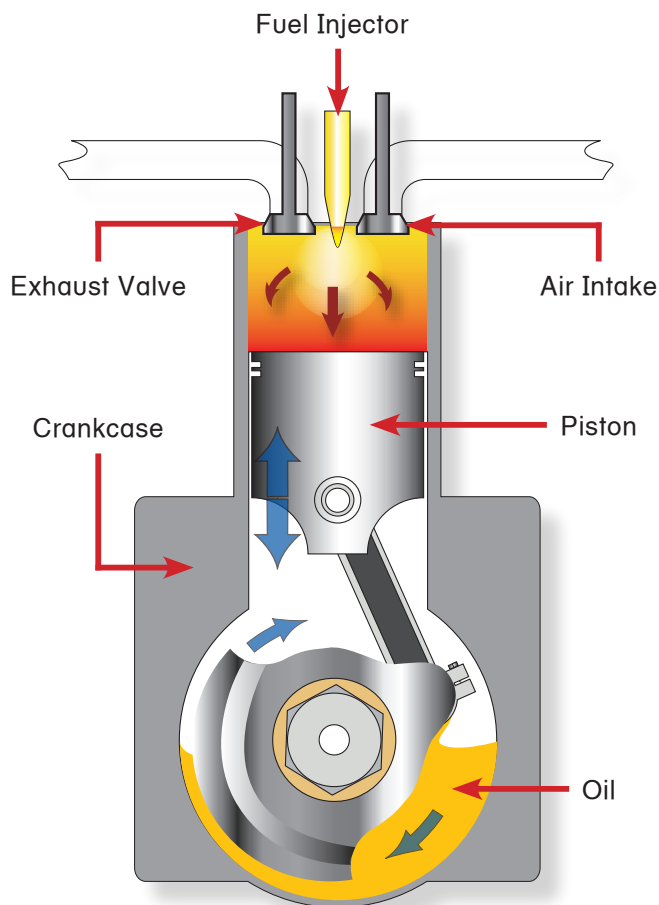

The crankcase, also known as the "oil galley" or "oil pan," is a dynamic place in the engine. It is the volume of space on the bottom end of the engine. It houses the crankshaft, pushrods, piston cylinders, pistons, connecting rods, and timing gears that connect to the front cover. Most of these components are moving, and a few are very hot. All the components come in contact with engine lubrication oil. This environment is where blow-by aerosols and particles are created in the following ways:

- Mechanical shearing the oil into droplets via the crankshaft and valve train,

- Boiling lube oil off of the hot piston and cylinder surfaces,
- Combustion gases themselves that leak by the metal piston rings.

Blow-by is a mixture of several distinct components. Some are gaseous, some are liquid, and some are particulate matter. Most of the components of blow-by are:

- Oil Aerosol Particles; 0.1 to 10+ μm
- Soot Particles; 0.3 to 0.5 μm
- Gasses; CO, CO₂, NO_x, O₂, H₂O
- Gaseous Hydro-Carbons (HC)
- Water Vapor (H₂O)
- Aldehydes

The items above are all of the products created during engine operation and have to be processed in order to meet the new emission guidelines. Engines equipped with breathers and "road tubes" expel all of these components to the atmosphere. Some of the gaseous components and the water vapor are not environmental concerns. However, the hydrocarbons, soot, and regulated emission gases are also expelled. These latter blow-by components are environmental pollutants that were allowed to exit the engine. In the 1970's blow-by emissions were a small portion of the overall emissions emanating from the engine. By the 1990's diesel emissions had been reduced to the point where blow-by emissions were a more significant portion of the total engine emissions. Regardless, the price to close the crankcase with more advanced filtration did not yet justify the reduction in oil consumption.

Two factors generated commercial interest for better performance in breathers. Open crankcases contaminate engine compartments with oily residue that builds up over time. Secondly, EPA emissions requirements indirectly force crankcase emissions to be dealt with prior to 2007.

Oil, soot, and other combustion components make operating environments in engine rooms of boats, gensets, and other environments undesirable. Genset can have radiators clogged with airborne debris and reduce cooling capacity when exterior radiator surfaces are coated with oil mist. Controls and operating environments for personnel are exposed to fine oil mist. In extreme cases, blow-by residue increases the possibility of exhaust stack fires on boats and gensets. Combined, these market forces created a niche market for ready fit CCV systems for OEMs, Outfitters, and private users alike.

EPA Emission Standards for Heavy-Duty Diesel Engines
(g/bhp•hr)

| Heavy Duty Diesel Truck Engines | | | | |
|---------------------------------|------------------|------|-----------------------------|------|
| Year | HC | CO | NO _x | PM |
| 1988 | 1.3 | 15.5 | 10.7 | 0.6 |
| 1990 | 1.3 | 15.5 | 6 | 0.6 |
| 1991 | 1.3 | 15.5 | 5 | 0.25 |
| 1994 | 1.3 | 15.5 | 5 | 0.1 |
| 1998 | 1.3 | 15.5 | 4 | 0.1 |
| 2004 option 1 | - | 15.5 | 2.4 NHHC+NO _x | 0.1 |
| 2004 option 2 | 0.5 NMHC only | 15.5 | 2.5 NHHC+NO _x | 0.1 |
| 2007 | 0.14 | 15.5 | 0.2 | 0.01 |

| Urban Bus Engines | | | | |
|-------------------|-----|------|-----------------|-------|
| Year | HC | CO | NO _x | PM |
| 1991 | 1.3 | 15.5 | 5 | 0.25 |
| 1993 | 1.3 | 15.5 | 5 | 0.1 |
| 1994 | 1.3 | 15.5 | 5 | 0.07 |
| 1996 | 1.3 | 15.5 | 5 | 0.05* |
| 1998 | 1.3 | 15.5 | 4 | 0.05* |

* - in-use PM standard 0.07

Tougher EPA (2007 and 2010 shown above) and Euro (Tier IV and V) requirements for NO_x, Hydrocarbon (HC) and particle emissions (PM) required diesel engine manufacturers to adopt technologies to lower emissions. These technologies include:

- Cooled Exhaust Gas Recirculation,
- Oxidation Catalysts,
- Adjusting Injector Timing,
- Turbocharging.

Advances in turbochargers and intercoolers required better crankcase blow-by oil separation. Breathers that allow oil aerosols to pass through to the turbocharger are baked onto turbo compressor housings. Oil deposits left on turbocharger compressors and intercooler interior surfaces eventually will cause problems. Coking of the oil residue alters compressor surfaces enough to change the compressor efficiency. Alternately, an oil coated intercooler does not transfer heat as well as a clean one. The effect of oil aerosol in the air induction system is power loss. Marine and power generation applications notice a reduction in peak power at

rated engine conditions. Off-highway and on-highway applications would notice reduced fuel economy of the engine.

For a decade, Racor has provided CCV filters to OEM's and the aftermarket. New emissions standards in 2007 require a 90% reduction in PM emissions for on-highway vehicles. For the first time, all emission points on the engine (exhaust pipe and crankcase emissions) are included.

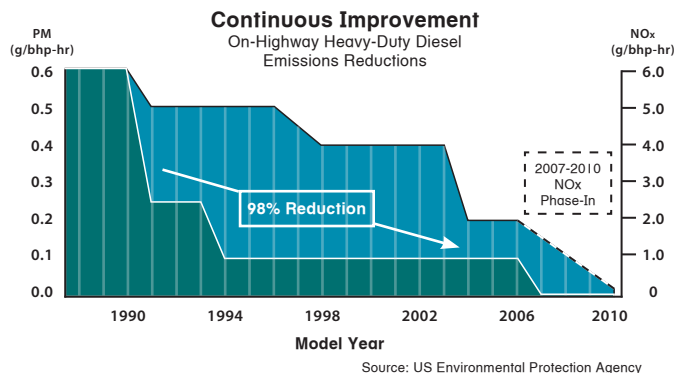

Racor CCV Assembly



Racor Closed Crankcase Ventilation (CCV) filtration systems are suited to fit a wide range of engine displacements and power ratings. We offer five models to the aftermarket that suit engines from 50 to 1600 HP. Larger units in tandem are used by OEM's on larger stationary gensets and on marine applications. Racor is in a position to supply any OEM with "off the shelf" CCV systems designed to meet 2007 EPA emissions regulations for closed crankcase, turbocharged, diesel cycle engines. These systems are in production and have been keeping the environment and engine air induction systems clean since 1997. Racor readily accommodates custom, integrated units for engines under development. We have the capability to work with OEM's to bring a completely new concept to bear.

History of Racor CCV

Beginning with a successful partnership of technology, filtration expertise, and customer focus, Racor released the first integrated CCV system for the diesel engine industry in 1997. The Racor CCV4500 was the first of four CCV units that marry several subcomponents:

- A pressure regulator,
- Filter element,
- Impactor/pre-separator in the pressure regulator,
- Optional bypass in the regulation valve,
- Filter change indicator,
- Drain to a remote mounted anti-suction check valve,
- Inlet and outlet ports with variable size options.

CCV systems integrate three distinct functions. The first is to provide coalescing and separation of oil mist particles, soot, and liquid volatiles created during the combustion process. CCV filter elements employ a depth loading media that has a very low pressure drop through the element, but increases the ability to coalesce particles out of the blow-by gas. With this, we are able to achieve very high efficiencies and maintain crankcase pressure between -4 to +4 in.H₂O on closed systems.

The second function is to provide a sump chamber and check valve which returns coalesced liquid oil back to the crankcase. Depending on the amount of carryover created by the engine, significant amounts of oil will be saved and returned to the crankcase. This lowers the overall maintenance cost of the engine, and protects the environment from contamination.

The third integrated feature of the CCV is the pressure regulation valve. It balances the pressure in the crankcase, protecting it from high vacuum created by a dirty air filter and today's high mass flow turbocharger compressors. Our pressure regulation valves monitor crankcase pressure ensuring that it maintains a range of -4 to +4 in.H₂O. These pressures are maintained throughout the operational life of the filter. On standard units, an integrated internal bypass feature is an option with our valve. It can be ordered, up front, with no additional cost to the customer. The valve also creates a pre-separation impactor surface when operating, which processes large droplet sizes above 10 micron. The valve system relies on ambient external pressure to regulate the blow-by gasses and does not require the introduction of outside air into the CCV system.

All of these components are combined into one robust package. Until this time, diesel engine OEM's were not offered technology more advanced than simple crankcase breathers. This previous technology was useful for limiting oil consumption by preventing liquid oil from being blown out of road tubes. Racor CCV filters provided diesel engine users a "systems" solution to eliminate blow-by emissions.



Closed System Crankcase Filtration

In 2003 Racor developed breathers to accompany the CCV product line. Breathers are used upstream of CCV devices to separate bulk liquid oil from the blow-by gas stream. Integrated in valve covers, or as bolt on units, they can process all but very fine aerosol concentration and keep the oil in the engine where it belongs.

In 2004, Racor expanded the development of closed crankcase ventilation in three areas:

- The ability to produce media in-house was adopted.
- New media development in cooperation from other Parker Hannifin divisions produced ultra high efficiency media with extended life.
- Fit for life breather products were enhanced with impactor technology.

All told, Racor has a myriad of solutions available for new OEM development. Racor CCV solutions stand soundly on a decade of experience in the field. New technologies in development include:

- Combined coalescing/impactor technology.
- Nano-fiber and mixed fiber diameter media are actively being researched.
- Value added integration of engine and chassis components with CCV technology.
- Other proprietary technology available for review with OEM engineering/purchasing.

Test Procedures

There are no final ISO or SAE test procedures for any aspect of CCV performance. ISO has been in committee for several years developing ISO/TC22/SC5, "Aerosol Separator Performance Test for Diesel and Petrol Engines." Two variants of this standard are being written for Bench and On-Engine testing. While industry and ISO meet to create test specifications, EPA 2007 and Euro IV engine development has been underway. Therefore, Racor has developed four test methods for measuring the performance of CCV or breather systems:

- Flow vs. Pressure Drop Test
- Crankcase Pressure Regulation Test
- On-Engine Gravimetric Efficiency Test
- Aerosol Distribution Efficiency Test

These tests depict overall performance of CCV devices on an engine and/or quantify the amount of aerosols removed.

Flow vs. Pressure Test (dry and saturated with oil)

This procedure creates a comparative set of data illustrating the usefulness of a medium for a CCV element. Two tests are performed. The first measures the pressure drop across a saturated element. This standard constitutes a benchmarking procedure. It is the first test performed on a medium because if the pressure loss required at a specific flow rate is too high, the element cannot be used. Crankcases are sensitive to positive pressures. The large oil pan area on engines cannot be subjected to positive pressures. Pressures in excess of the manufacturers recommendations may cause an oil pan seal, crankshaft seal, or valve cover seal leak. If favorable results are achieved with this test, an initial efficiency test should be performed on the sample media.

Racor CCV3501: High Efficiency Element Closed Crankcase Filter System Flow vs. Pressure Drop Curves

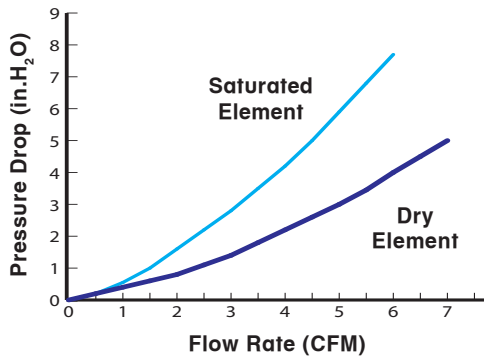

Notes:

1. The CCV system uses the vacuum created by the air induction system to overcome the differential pressure of the filter element.
2. Filter efficiency is dependent on specific engine design and application, as well as speed and load requirements.

Typical data depicting a new CCV element, and the same element saturated.

Pressure Regulation Test

This procedure creates a set a data illustrating the performance of the CCV pressure regulation valve. The test determines if the regulator is functioning to design specifications. This standard ensures the system is designed properly. Crankcases are sensitive to positive and negative pressures. The large oil pan area on engines cannot be subjected to positive pressures. Pressures in excess of the manufacturers recommendations (both positive or negative) may cause an oil pan seal, crankshaft seal, or valve cover seal leak, or pull in unfiltered dust from the outside atmosphere.

Pressure Regulator Tests Constant Flow Rate of 3.0 SCFM

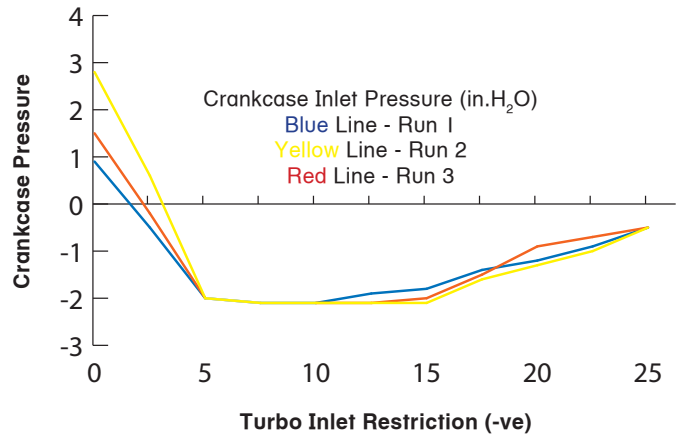

Typical crankcase pressure data depicting performance of the pressure regulator over three trial runs at 3 CFM of a CCV3501 unit with varying inlet restrictions.

On-Engine Gravimetric Efficiency (isokinetic sampling) On-Engine Particle Distribution Analysis

This procedure establishes the CCV element or breather efficiency for particles over 0.3 micron. The efficiency is gravimetric and pertains to the particles entrained in the air stream which enter and leave the CCV device. This type of efficiency is a good indicator of overall performance for a unit on an actual engine where the challenge aerosol contains oil droplets and solid soot particulate. It will reflect the actual loading and of aerosol particles and release of coalesced oil in the real world setting.

This standard contains instruction for a test that evaluates the key function of the media. It is the second test performed on a medium. A 50 liter sample of air is taken upstream and then downstream of the filter. Both samples pass through the laboratory papers and the weight upstream and downstream is recorded. From this data, we can calculate the carryover of particles that remain entrained in the gas stream. The challenge rate and carryover in grams per hour is found and gravimetric efficiency over the 50 liter sample is established. The particle distribution analysis is performed with a laser spectrometer or a coronal cascade impactor. The sampling technique is similar. An isokinetic sample is diluted approximately 100 times, and passed through the measurement instrument.

Particle Distribution vs Efficiency (Racor Aerosol Test Bench)

The particle distribution curve below is a sample set of data taken from the automated test stand. Both gravimetric efficiencies and particle distribution curves can be generated. The test stand has a heated, temperature controlled environment in which aerosols are generated. A laser particle spectrometer takes upstream and downstream measurements. The stand has capability to conduct:

- Total separation efficiency measured gravimetrically,
- Fractional separation efficiency.

The test stand also performs pressure regulation tests and flow vs pressure drop. These tests are valuable for research, development, and validation of a design when compared to on-engine results.

| Gravimetric Efficiency Calculation | | | |
|------------------------------------|--------|---------------------|----------------|
| 360 liters/minute (12.6 CFM) | | | |
| Particle Size (µm) | % Mass | Impactor Efficiency | % Carryover |
| 0.375 | 1.7 | 8.171 | 1.561093 |
| 0.45 | 7 | 53.3 | 3.269 |
| 0.55 | 11.9 | 71.94 | 3.33914 |
| 0.65 | 4.9 | 81.3 | 0.9163 |
| 0.75 | 9.2 | 87.09 | 1.18772 |
| 0.9 | 10.4 | 90.94 | 0.94224 |
| 1.25 | 18.2 | 95.01 | 0.90818 |
| 1.75 | 12.3 | 98.36 | 0.20172 |
| 2.5 | 7.8 | 100 | 0 |
| 3.5 | 16.6 | 100 | 0 |
| 4.5 | 0 | 99.84 | 0 |
| 7.5 | 0 | 100 | 0 |
| Gravimetric Efficiency | | | 87.6746 |

Impactor Efficiency vs Particle Size at Fixed Flow Rates

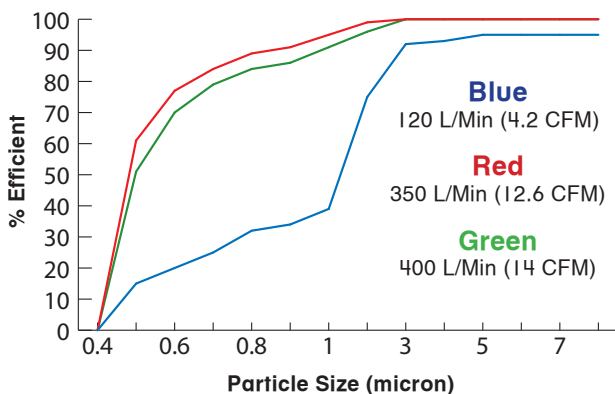

Racor Test and Engineering



Racor Test and Engineering Facilities:

Modesto, California

- Division Headquarters
- Research and Development
- Project Engineering
- Bench Testing and Engine Dyno Testing

Holly Springs, Mississippi

- CCV Manufacturing Location
- Product and Project Engineering

Dewsbury, United Kingdom

- Research and Development
- Project Engineering
- Bench Testing, Automated Aerosol Testing

New manufacturing-engineering facilities are opening within existing Parker Hannifin manufacturing locations in:

- Gangnam-Ku, Seoul, South Korea
- Shanghai, China

A range of proven test methods afford Racor customers with the best CCV systems on the market. Ongoing engineering efforts and worldwide collaboration with customers allow Racor to address customer issues wherever they may be and keep a pulse on customer needs as world markets merge.

Racor engineering can visit your customer site to perform an onsite measurement of any engine on a dynamometer. Please consult your application engineer to schedule an appointment.

CCV Types, Function, and Relative Costs

Several types of closed crankcase ventilation devices exist on the market today. Many of those devices are very different from the Racor product offering. Implementing another emissions control device to an engine can be a costly exercise. When considering the cost implications, many factors must be decided about the technology that effect the efficiency, purchased price, cost of installation, cost to the end user, price in power consumption and fuel.

Device Effectiveness or the Efficiency of Oil Separation

What is the desired efficiency range required to maintain desired power conditions and meet new emissions requirements?

Purchased Cost of Unit

Many sophisticated units can be designed and integrated into an engine, but what is the realistic performance vs. cost criteria of the CCV system?

Cost of Installation

Purchasing any type of device may have external hoses, or valuable package room required in engine space. These costs are in addition to the price of the unit.

Service Requirements

What are the acceptable change intervals for servicing the CCV device?

Will the unit have a high efficiency changeable filter to protect the turbo?

Does the customer want a fit for life unit at the expense of the turbo?

Parasitic Power Consumption

Extended service intervals may require a device that is driven mechanically or by a separate electric motor. What is the overall fuel consumption required to do this? Running a device equivalent to a 70 watt light bulb on an engine costs more in fuel than the cost of a service element in the time the service element would be changed.

The chart to the right shows many CCV devices available on the market today and the relative choices in selecting a unit.

CCV Types, Function and Relative Costs

| Device | Efficiency | Cost | Service Requirements | Parasitic Engine HP Losses |
|----------------------------------|--------------------------------|----------|------------------------------|----------------------------|
| Non-Driven Cyclone | Low Efficiency | \$ | No | No |
| Impactors | Low - Good Efficiency | \$ | No | No |
| Simple Breather | Lowest Efficiency | \$ | No | No |
| Coalescing Separation Filtration | Good to Excellent | \$\$ | Yes | No |
| Electrostatic Filter | Good, But Not Consistant | \$\$\$ | No High Service/Repair Costs | Yes |
| Driven Centrifuges | Good, Requires High RPM Device | \$\$\$\$ | No High Service/Repair Costs | Yes |
| Crankcase to DPF Pump/Separator | Good to Excellent | \$\$\$\$ | May Have Replaceable Element | Yes |

Racor specializes in Coalescing Separation Filtration. It has the best performance for economy out of all the competing technologies. Given any maximum allowable crankcase pressure, a coalescing filter will provide the greatest efficiency over any other technology. The crankcase pressure is proportional to the level of efficiency. New developments in media technology are reducing the threshold of crankcase pressure required to achieve higher and higher efficiencies.

CCV Media, Types, Advantages and Disadvantages

Air Filters vs. CCV Filters: The Differences

Filtering the aerosols from the blow-by gas is only half of the requirements for media. Once the oil has collected in the media, it must be released. For any given flow rate and upstream pressure on the media, a specific saturation level is achieved. Media saturated with oil is very different than media plugged with dust or dirt. Here is where the CCV filter departs from any similarity with air filters. The two are often confused by customers and our competitors alike. Although the fluid that flows through a CCV media is gaseous and mostly air, the CCV filter is primarily a coalescing filter, not a particle trap like an air filter. Air filters rely on the impaction of particles to separate the solids from the air stream. Air filters also use the dirt itself to create a surface cake of particles to sieve more particles from the air passing through the pleated walls of the medium.

The life expected in a CCV filter has to do with its ability to drain oil. Engine air filters typically provide ample

surface area to collect numerous amounts of particles. CCV filters must coalesce aerosols to collect an amount of liquid downstream. Oil is a liquid. When oil is in aerosol form, it is still a liquid. As aerosol particles join together in the media, they pool together. The pools are formed into droplets, and the droplets eventually are pushed to the downstream side of the media. As the droplets grow, they are shed out of the media and trickle off of the outer surface. This process of growing small particles into droplets and shedding them is the act of coalescing.

What makes CCV applications unique?

Coalescing a liquid from a gas stream is done in many industrial settings. The uniqueness of CCV filtration verses industrial coalescing applications is the intolerance for internal pressures. It is not uncommon to achieve 99.9% efficiency coalescing oil out of industrial compressed air systems. This is achievable due to excellent media with high differential pressures (approximately 5 PSI). CCV systems cannot handle the same differential pressures. Oil pans, head gaskets, rocker cover gaskets, and engine shaft seals are all susceptible to crankcase pressures that pale in comparison to compressed air systems. A human can produce enough lung pressure through a soda straw to exceed many engine manufacturers' allowable crankcase pressures (8 in.H₂O). More modern engine designs allow for higher crankcase pressures, but almost none exceed 1 PSI (27.8 in.H₂O). The pressure loss across the filter element is directly tied to the ability of the media to shed oil. All filter medium rely on the crankcase pressure to push coalesced oil out of the media.

Thin-Walled Media: Saturation and Oil Release in Elements

Thin-walled medium are great at stopping particles. However, because of the matted construction, oil droplets bridge the fibers and form a wall that does not easily shed oil. High efficiencies are possible, but life is very short. During operation, a new element saturates with oil. The saturated wall of oily media quickly exceeds allowable cc pressures. If the engine were to shut off at this point, no oil would have been shed by the media. At shutdown, the required differential pressure to push the oil off the thin-walled media was never reached. Many thin-walled medium *initially* test very well. A clean element tends to absorb oil mist particles. The absorption of these particles yields almost no downstream particles. Therefore, the initial efficiency is very high. Once the 'wall of oil' forms, the pressure drop surges. Once the upstream pressure exceeds the oil release boundary, the efficiency falls because the oil droplets blow through the media, and coalescence does not occur with great efficiency.

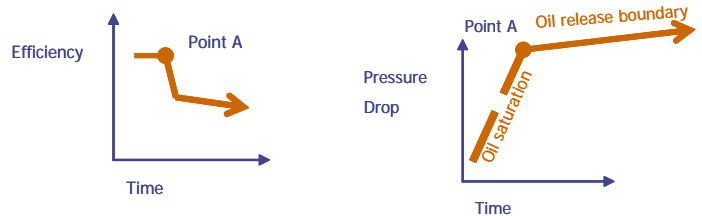

Depth Loading Media: Saturation & Oil Release in Elements

Thick-walled medium are uniquely suited to coalesce aerosols. Depth loading media is meant to operate at a permanently saturated state over the life of the element. Saturation is dependent on the flow rate of the system. A new element absorbs aerosol until a level of saturation is reached. Point A below shows the point where the element stops absorbing the coalesced droplets and begins to shed oil. After the initial release of oil from the newly saturated element, the efficiency may fall by as much as 10%. The fall uncovers the masked performance of the element while the new element is busy absorbing oil droplets. The initial rise in pressure drop is very low during the absorption phase. As the element is used, assuming a constant flow rate, a steady saturation level is maintained as oil droplets are coalesced and shed. Continued use of the element will produce a slightly elevated efficiency from Point A. As dirt clogs the element, pressure drop begins to build until the element pressure drop exceeds the system limit.

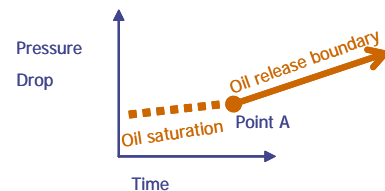

What ends the life of depth loading media?

The answer is soot. Depth loading media performs so well because they require aerosols to weave around many glass fibers. Along with the aerosols comes soot. Soot is a by-product of engine combustion. It is made entirely of carbon, and is not a liquid. The soot in the media does not necessarily drain well from the media. The solid particles begin to build up as the element continually saturates and releases oil. Over time the soot begins to fill the voids in the matrix and the pressure drop across the element begins to rise. This eventually requires the media to be replaced.

Factors that effect soot loading:

- Cooler combustion temperatures created by EGR. Cooler exhaust gas results in incomplete combustion, and higher soot content in the exhaust gases.
- Rich combustion.
- Poor piston ring sealing.
- High piston temperatures on the bottom surface. Oil flashes and boils on these surfaces.
- Burning of multi-viscosity oils and organic additives.

Racor media formulations include glass micro-fiber. New research is being done with a nano-fiber medium. As a depth loading material, nano-fibers are not very successful at meeting the low pressure drop requirements for CCV applications. Further advancements in blended micro-fiber and nano-fiber mixtures yield more promising results. One of the more attractive qualities of nano-fibers is that they are formed with nylon polymers. Nylon fibers can be disposed of more easily than glass fibers.

Racor Patented Pressure Regulation

Racor patented pressure regulation leads the industry. Engine turbochargers change inlet restriction according to the following graphs:

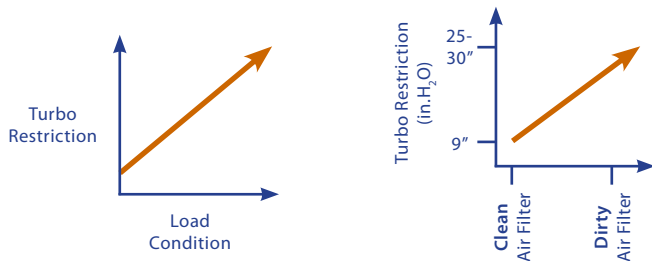

As the turbocharger compressor pulls more air through the engine air filter, a vacuum is created. This vacuum is referred to as an air or turbo "restriction." This restriction is translated to the crankcase via the closed crankcase system, unless a pressure regulator is present. The pressure regulator is designed to reference atmospheric pressure and limit the exposure of the turbo restriction to the crankcase. Racor CCV pressure regulators limit vacuum in the crankcase to -4 in. H₂O. Conversely, if the optional bypass installed the pressure regulator will begin to vent positive crankcase pressure at 4 in. H₂O. The valve is constantly dithering to correct and control crankcase pressure as the turbo restriction changes, and the crankcase flow rate changes. Blow-by flows out of the crankcase at different rates.

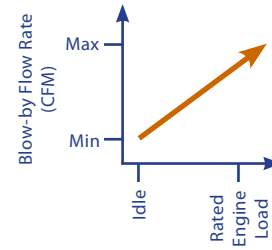

As the engine runs, blow-by is being created. The blow-by never stops entering the crankcase from the piston chamber. As the load on the engine increases, so will the flow rate of the blow-by.

The placement of the pressure regulator in the system will affect the life of the CCV filter. Racor places the pressure regulation valve in a location that is ideal for optimizing element life and closely monitoring crankcase pressure. The ideal Racor system and a less advantageous system are described below.

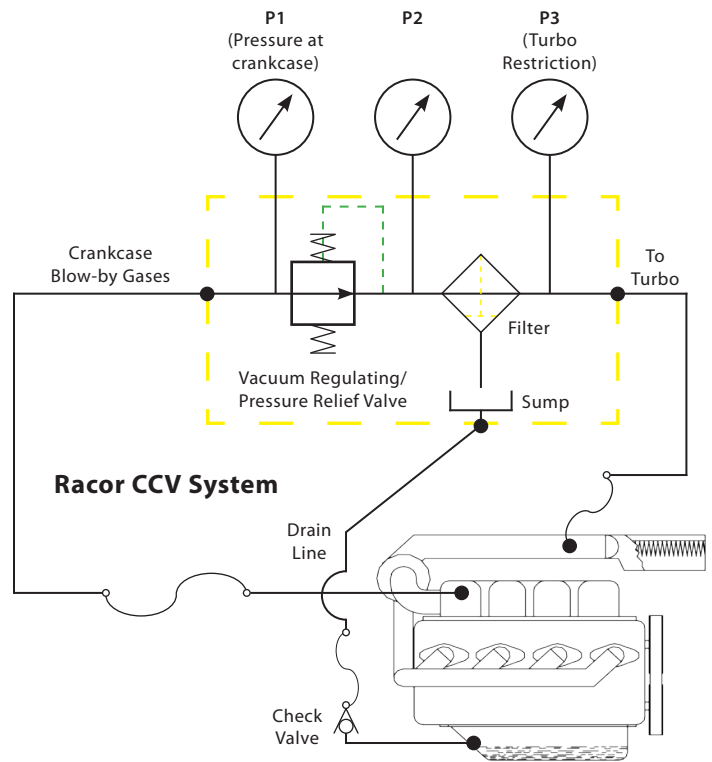

Shown in the picture above, the Racor pressure regulator is upstream of the filter. This ensures that the pressure regulator is always regulating the crankcase pressure. The turbo restriction measured at P2 is reduced by the pressure drop created by the element $\Delta P = P3 - P2$. The pressure that the valve regulates is between P1 and P2, the ΔP across the element never effects the crankcase pressure. The turbo restriction extends filter life by pulling as much coalesced oil out of the element.

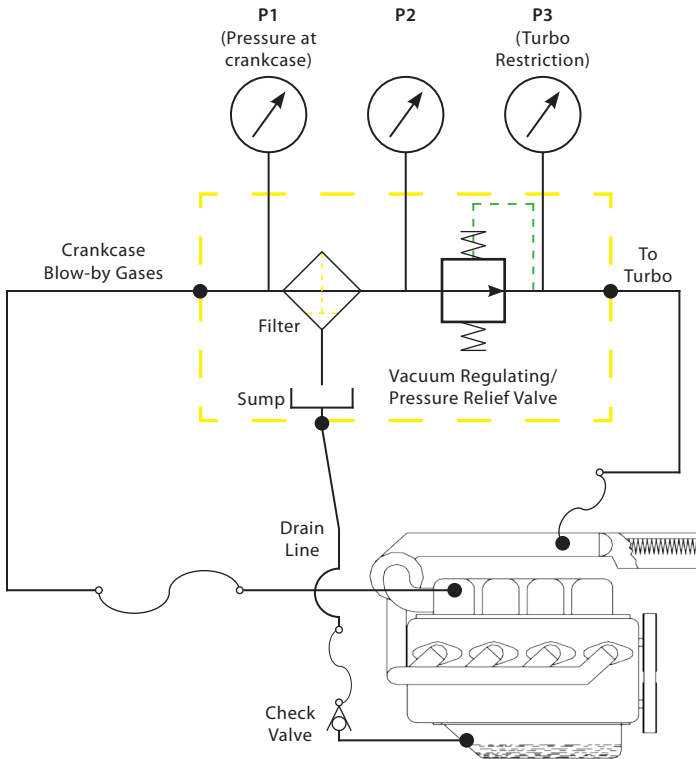

The picture above shows how placing the regulator downstream of the filter element hinders the ability of the regulation valve to properly regulate the crankcase pressure. In this configuration, the regulator is regulating the pressure drop across the filter element, not the crankcase pressure. As the filter element plugs, the crankcase pressure increases to higher levels. Unfortunately, the pressure regulator blocks the turbo restriction from reaching the element and the crankcase becomes over pressurized and the filter has to be changed at very short intervals.

Pressure Regulator Performance

The regulated crankcase pressure is unaffected by change in media pressure differential during its life cycle. This is because both dynamic variables (turbo suction and media pressure drop) are on the input side of the control device. This is illustrated in the charts below for both a clean and blocked element. Over a range of flow rates and turbo operating points, the output remains between -0.8 to -4.0 in.H₂O (-2 and -10 mbar).

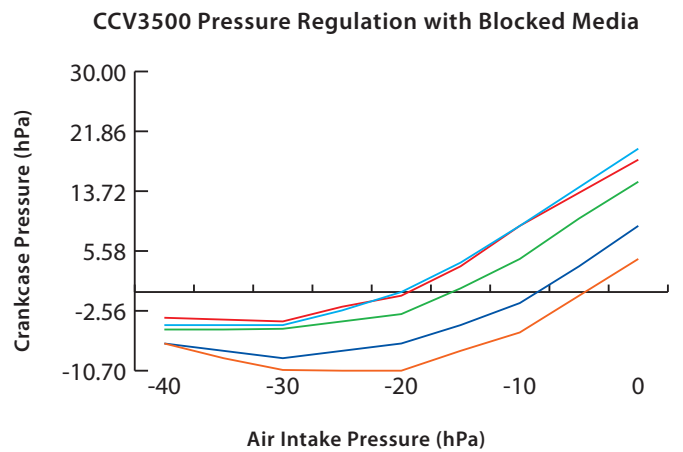
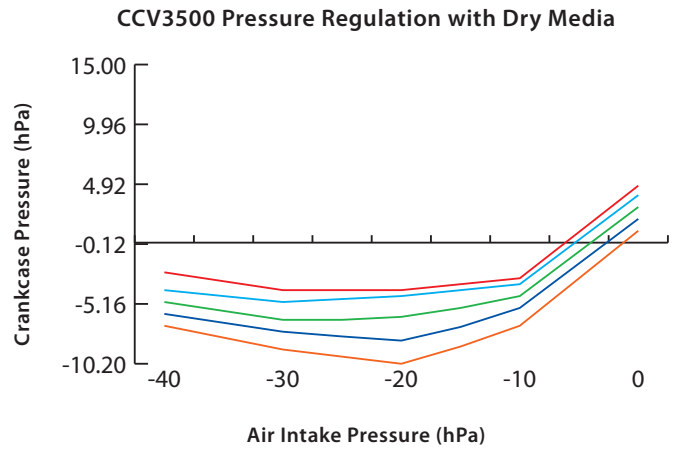

Operation without a pressure regulator exposes the outlet of the CCV separator to the full brunt of the turbo restriction. The detrimental effect is that oil can be pulled out of the crankcase because turbo restriction is translated directly to the crankcase. Only the ΔP across the separator protects the crankcase from large negative pressures. The possibility of seal failure, and dust ingestion to the crankcase increases. The max turbo restriction is -25 to 30 in.H₂O (-62 to 75 mbar). The separator may have as little as 10 in.H₂O of ΔP at max blow-by flow. That leaves the balance of the pressure differential to challenge the oil pan seals.

Racor pressure regulators have been protecting engines all over the world since the product inception. Diesel engine, CNG, LNG engines, and hydrogen fueled engines have all been protected by the patented Racor pressure regulator integrated into our "off the shelf" designs. Specific pressure settings can be configured to suite particular engine needs.

Racor Inertial Separators (Impactors)

All inertial separators operate on the same principle. An aerosol is passed through a nozzle and the output stream (jet) directed against a flat plate. The flat plate deflects the flow to form an abrupt bend in the streamline. Particles whose inertia exceeds a certain value are unable to follow the streamline and collide (impact) with the flat plate.

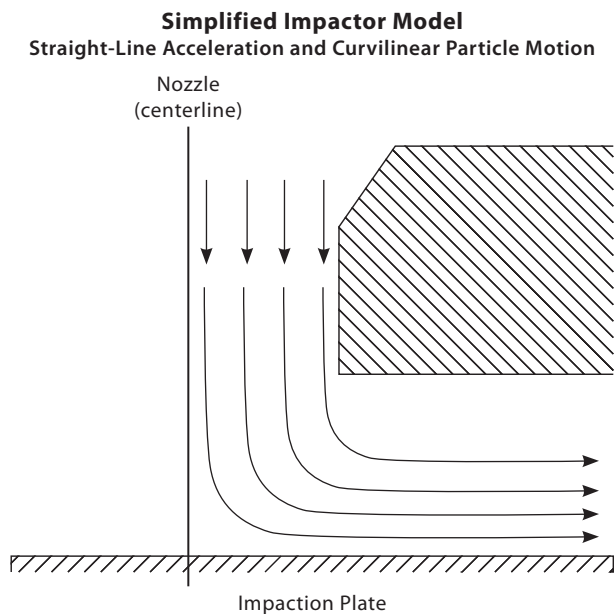

Idealized, all oil aerosol particles that are separated from the streamlines coalesce from a film that is able to drain from the collection surface. Real life results generate two other possibilities.

1. Particles with significant inertia may bounce off the collection plate and re-entrain themselves in the exiting streamline.
2. Particles too small to be fully effected by the abrupt change in direction proceed past the collection plate without being separated.

It is for these two cases that Racor supplements the inertial separation with a media in the full flow path of the exit gases, bridging the entire volume of the exit flow path. The presence of the depth loading media provides coalescing for particles that would not otherwise be separated. Design parameters such as gas and aerosol particle Reynolds number, temperature, orifice size, and many secondary parameters are examined to optimize the performance of the separator.

The operation of inertial separators are largely dependent on velocity, and therefore flow rate. The disparity in performance between coalescers and impactors show itself when sizing a unit to an engine

with widely varying flow rates. A new engine typically has half the blow-by flow rate of an older worn engine. This is primarily due to piston ring wear and loss of compression. Even with that, the flow rate at idle can be 1/4 of the flow rate at rated load and speed. So over the life of an engine, the blow-by flow rate can exceed a 8:1 turn down ratio between. The limits of this 8:1 ratio exist at the following conditions:

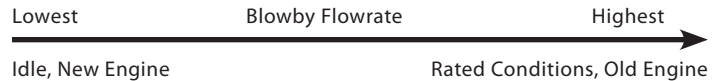

Although an inertial separator has performance deficiencies compared to a replaceable element coalescer, they provide great economy and are easily altered to meet tight packaging constraints. Racor can design very small separators for use on an engine that integrate engine components such as oil fill ports, valve covers, etc. Simpler designs can function as breathers on large engines, and as final units when efficiency that is sub-par to a coalescing filter is permitted.

CCV Heaters

Racor CCV heater kits are an optional accessory for engine applications operating in severe weather. In cold weather applications, the gases and vapors processed by the CCV systems are affected by ambient conditions. The freezing air that has passed through the engine compartment, by the radiator fans, force the canister to function as a heat sink for the crankcase gases. The canister is cooled to ambient temperature and oil mist and water vapor particles traveling through the CCV system will then coalesce against the cold interior surfaces of the CCV canister. This process introduces microscopic particles of oil and water to each other. When they mix, an emulsification of the two liquids occurs. This emulsification turns the two particles into a creamy jelly-like substance. The mixture slowly builds up as cold air continually cools the canister and the process repeats itself. The emulsified oil-water mixture collect to a point where element life is compromised and crankcase pressure will rise.

The preceding information was provided by Tom Tomchak, Racor CCV Engineering Manager, and the Racor Engineering Team.

To learn more about Parker Racor's complete line of Crankcase Ventilation Filtration Systems and the specific CCV™ product for your application, please contact www.racorengus.com.

Parker Racor has a global network of engineering, manufacturing and service locations that are listed on the outside back cover of this publication.

The following article is reprinted with permission from the January/February 2006 edition of Diesel Progress International and the February 2006 edition of Diesel Progress North America.

BY MIKE OSENGA

Clean Air Regulations Drive Racor's Crankcase Filtration Line

Over the past decade, legislative efforts have accelerated to mandate the closing of diesel engine crankcases and eliminate the venting of their emissions into the atmosphere. The EPA's Tier 3/ Tier 4 and equally stringent European emissions regulations are now in place and more countries are moving forward with clean air legislation. To meet global engine manufacturers' requirements to comply with the standards, the Racor Division of Parker Hannifin Corp. has expanded its CCV line of closed crankcase filtration systems as well as its engineering design teams and manufacturing operations.

Racor, Modesto, Calif., has recently added two new models, the CCV1500 and CCV3500 to the lower horsepower range of its crankcase filtration line, joining the larger CCV4500, CCV6000 and CCV8000 models. Single units in the Racor line are designed to handle crankcase flows from 0.5 cfm to 40 cfm and manifold systems can expand that capacity, the company said. Racor said it is also working with OEM customers to engineer and manufacture custom CCV filtration systems for specific space requirements and operating conditions.

Reflecting global interest in closing diesel engine crankcases, the Racor Division of Parker Hannifin has added two new models, the CCV1500 and CCV3500, to the lower horsepower range of its crankcase filtration line.

The new CCV3500 is rated at 3.0 cfm on new engines in the 20 hp to 200 hp ranges, while the CCV1500 has a 1.0 cfm capability and is typically used on smaller engines up to 40 hp.

The CCV3500, which fits into a 7 in. high x 6.3 in. deep x 7.0 in. maximum opening width area, has an integral crankcase pressure regulator and weighs 2.3 lb. The CCV1500 is 5.1 in. high x 5.6 in. deep with a maximum opening width of 8.2 in. It weighs 1.5 lb. and uses a vacuum limiting valve to regulate crankcase pressure.

The key driver in this increased global interest in closing diesel engine crankcases is that for virtually all on- and off-highway diesel regulations, those emissions are now added to the exhaust count when measuring a specific engine for compliance. It is not just what comes out of the tailpipe any longer, but the total emissions an engine generates, by whatever source.

This is especially true as regulatory attention now begins to look toward



engines in operation. As engines wear, crankcase emissions increase and closing the crankcase with a filtration system is one of the primary technologies being used to keep engines in compliance.

The marine markets, specifically propulsion engines and standby generator sets, have long used crankcase ventilation filtration systems to improve equipment efficiency and provide safe air quality in tight quarters. That interest is now expanding into almost every type of diesel application. The on-highway markets have led the movement, but there is also increasing interest off-road.

With a CCV system being closed-loop by design, Racor said, crankcase blow-by is processed through various separation and filtration stages and re-enters the combustion process via the turbocharger. This requires designers to be more aware of pressures in the crankcase. Racor's design includes a patented pressure regulating valve mounted upstream that maintains a slightly negative crankcase pressure.

Racor said this design maintains crankcase pressure independently of changes in the filtration system's pressure drop and in turn sustains crank-

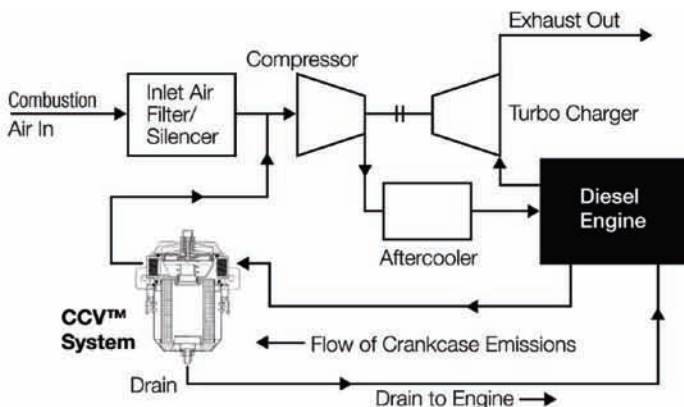

Crankcase blow-by is processed through various separation and filtration stages and re-enters the combustion process via the turbocharger.



Parker Hannifin UK Ltd. has developed a custom-built test rig that generates aerosol as measured on an engine.

case pressure over all engine speeds and loads.

The current emission regulations and tighter EPA standards pending for 2007 has guided the International Organization for Standardization (ISO) to develop a worldwide accepted test standard, ISO 20564, for the engineering of CCV devices. A key component of the standard, said Racor, is the ability to measure filter performance, especially as its testing has shown that

nearly 70% of oil in diesel blow-by is sub-micron in size.

Racor's CCV system design, which includes several new media technologies expected to be introduced this year, has focused on particles in the 0.2 to 0.4 micron range which it said are the most difficult to separate while still providing adequate filtration life.

Among the global OEM customers using Racor CCV filtration systems are Ford, ITEC, John Deere, Caterpillar, DaimlerChrysler, Case New Holland, Case MXM, Shanghai Diesel, HeNan Diesel and others. The Racor CCV systems are also being installed through retrofit programs on busses, marine engines and generator sets.

As part of Racor's global expansion, Parker Hannifin U.K. Ltd., Dewsbury, West Yorkshire, has developed a custom-built test rig that generates aerosol as measured on an engine. With gravimetric, fractional efficiency, pressure drop and pressure regulation validated, allowing the testing of proto-

types, often on specific engines, to be carried out with faster development times, Racor said. A portable element of this test rig can also be used to perform on-site tests.

At the same time, as with "systems engineering" in most parts of the engine and equipment market, Racor utilizes a fused deposition modeling (FDM) machine to produce rapid prototypes for customer evaluation.

Along these lines, Racor said it has been developing CCV packages with integral valve covers and other individual proprietary designs. Racor said the package designs allow system integration and overall improved performance and cost savings for OEM and aftermarket customers. **dp**



Parker Filtration Group Engineering, Manufacturing & Service Locations

Parker Worldwide Sales Offices

Contact Parker's worldwide service
and distribution network by calling:

Filtration Group Headquarters

6035 Parkland Blvd.
Cleveland, Ohio, 44124-4114 USA
Tel: (216) 896-3000
Fax: (216) 896-4021
www.parker.com/filtration

Filtration and Separation Division Balston Products

242 Neck Road
Haverhill, MA 01835-0723 USA
Tel: (978) 858-0505
Fax: (978) 858-0625
www.parker.com/balston

Filtration and Separation Division Finite Filter Products

500 Glaspie Street
P.O. Box 599
Oxford, MI 48371-5132 USA
Tel: (248) 628-6400
Fax: (248) 628-1850
www.parker.com/finitefilter

Hydraulic Filter Division

16810 Fulton County Road #2
Metamora, OH 43540-9714 USA
Tel: (419) 644-4311
Fax: (419) 644-6205
www.parker.com/hydraulicfilter

Process Advanced Filtration Division

6640 Intech Boulevard
Indianapolis, IN 46278 USA
Tel: (317) 275-8300
Fax: (317) 275-8413
www.parker.com/processfiltration

Parker Hannifin GmbH & Co KG

Inselstrasse 5
D-70327 Stuttgart-Wangen Germany
Tel: +49 (0) 711 7071 290-10
Fax: +49 (0) 711 7071 290-70
www.parker.com/racor

Racor Division Global Headquarters

3400 Finch Road
P.O. Box 3208
Modesto, CA 95354 USA
Toll Free: (800) 344-3286
Tel: (209) 521-7860
Fax: (209) 529-3278
www.parker.com/racor

Beaufort, SC, USA

Tel: (843) 846-3200

Holly Springs, MS, USA

Tel: (662) 252-2656

Parker Hannifin Industria e Comercio Ltda. Filtration Division

Estrada Municipal Joel de Paula, 900
Eugenio de Melo, São José dos Campos
CEP 12225-390 SP Brazil
Tel: +55 (12) 4005 3500
Fax: +55 (12) 4009 3529
www.parker.com/br

Parker Hannifin Shanghai Co. Ltd.

280 YunQiao Road
JinQiao Export Processing Zone
Shanghai 201206 China
Tel: +86 21 5031 2525
Fax: +86 21 5834 3714
www.parker.com/china

Parker Hannifin Thailand Co. Ltd.

1023 3rd Floor, TPS Building
Pattanakarn Road
Suanluang, Bangkok 10250 Thailand
Tel: +66 2717 8140
Fax: +66 2717 8148
www.parker.com/thailand

Parker Hannifin Corporation India

Plot EL 26, MIDC, TTC Industrial Area
Mahape, Navi Mumbai 400 709 India
Tel: +91 22 5613 7081
Fax: +91 22 2768 6841
www.parker.com/india

Parker Hannifin UK Ltd.

Filter Division Europe
Shaw Cross Business Park
Churwell Vale
Dewsbury, WF12 7RD England
Tel: +44 (0) 1924 487000
Fax: +44 (0) 1924 487038
www.parker.com/eurofilt

Parker Hannifin Oy Filtration Division

Salmentie 260
FI-31700 Urjala as. Finland
Tel: +358 20 753 2500
Fax: +358 20 753 2501
www.parker.com/fo

domnick hunter Division

Durham Road, Birtley
Co. Durham, DH3 2SF England
Tel: +44 (0) 191 410 5121
Fax: +44 (0) 191 410 2532
www.domnickhunter.com

Parker Korea Ltd.

777 Jung-Ri
Dongtan-Myeon, Hwaseong-City
Kyunggi-Do, 445-813 Korea
Tel: +82 31 379 2200
Fax: +82 31 377 9710
www.parker.com/korea

Parker Hannifin Africa Pty Ltd.

Parker Place, 10 Berne Ave, Aeroport
Kempton Park, 1620 South Africa
Tel: +27 11 9610700
Fax: +27 11 3927213
www.parker.com/ea

Parker Hannifin Japan Ltd

626, Totsuka-cho, Totsuka-ku
Yokohama-shi, 244-0003 Japan
Tel: +81 45 870 1522
Fax: +81 45 864 5305
www.parker.com/japan

Argentina • +54 (11) 4752 4129

Australia • +61 (2) 9 634 7777

Austria • +43-2622-23501-0

Belgium • +32 (67) 280900

Brazil • +55-12-3955-1000

Canada • 1-800-272-7537

Central & South America/Caribbean • 1-305-470-8800

China • +86 (21) 6445 9339

Czech Republic • +42-0-2-830-85-221

Denmark • +45-0-43-56-04-00

Finland • +358 (0)3 541100

France • +33-0-254-740304

Germany • +49-0-2131-4016-0

Hong Kong • +852 (2) 428 8008

Hungary • +36 (1) 252 8137

India • +91-22-790-7081

Italy • +39-02-451921

Japan • +81-3-6408-3900

Jordan • +(962) (6) 810679

Korea Choongnam • +82-41-583-1410

Korea Kyounghnam • +82-55-389-0100

Korea Seoul • +82-2-559-0420

Mexico • 1-800-272-7537

Netherlands • +31-0-541-585000

New Zealand • +64 (9) 573 1523

Norway • +47-64-91-1000

Poland • +48-22-863-4942

Singapore • +65 6261 5233

South Africa • +27 (11) 9610700

Spain • +34 (91) 675 7300

Sweden • +46-8-5979-5000

Switzerland • +41-0-22-307-7111

Taiwan • +886(2) 2298 8987

Thailand • +66 2717 8140

United Arab Emirates • +971-2-6788587

United Kingdom • +44 (0) 1924-487000

USA • 1-800-272-7537

Venezuela • +58-212-238-54-22

RACOR®

Parker Hannifin Corporation
Racor Division
P.O. Box 3208
Modesto, CA 95354 USA
Tel: 800-344-3286
Fax: 209-529-3278
<http://www.parker.com/racor>
E-mail: racor@parker.com



anything possible

Bulletin RCR01-7678/US
IM 03/2006
© All rights reserved.